

Table of Contents

Chapter - 1 Fundamentals of Electricity	(1 - 1) to (1 - 104)
1.1 Introduction.....	1 - 1
1.2 The Structure of Matter.....	1 - 1
1.2.1 Structure of an Atom.....	1 - 2
1.3 Concept of Charge.....	1 - 3
1.3.1 Unit of Charge.....	1 - 4
1.4 Concept of Electromotive Force and Current.....	1 - 4
1.5 Relation between Charge and Current.....	1 - 5
1.6 Concept of Electric Potential and Potential Difference.....	1 - 6
1.7 Electromotive Force and Potential Difference.....	1 - 7
1.8 Resistance.....	1 - 8
1.8.1 Factors Affecting the Resistance.....	1 - 10
1.9 Resistivity and Conductivity.....	1 - 10
1.9.1 Conductance (G).....	1 - 11
1.9.2 Conductivity.....	1 - 11
1.10 Effect of Temperature on Resistance.....	1 - 14
1.10.1 Effect of Temperature on Metals.....	1 - 14
1.10.2 Effect of Temperature on Carbon and Insulators.....	1 - 15
1.10.3 Effect of Temperature on Alloys.....	1 - 15
1.10.4 Effect of Temperature on Semiconductors.....	1 - 16
1.11 Resistance Temperature Coefficient (R.T.C.).....	1 - 16
1.11.1 Unit of R.T.C.....	1 - 18
1.11.2 Use of R.T.C. in Calculating Resistance at $t^{\circ}\text{C}$	1 - 18
1.11.3 Effect of Temperature on R.T.C.....	1 - 19
1.11.4 Effect of Temperature on Resistivity.....	1 - 20

1.11.5 R.T.C. of Composite Conductor	1 - 23
1.12 Insulation Resistance	1 - 28
1.12.1 Insulation Resistance of a Cable	1 - 29
1.12.2 Effect of Temperature on Insulation Resistance	1 - 31
1.12.3 Effect of Moisture on Insulation Resistance	1 - 32
1.13 Fundamental Quantities and Units	1 - 32
1.13.1 Mechanical Units	1 - 32
1.13.1.1 Relation between Torque and Power	1 - 33
1.13.2 Electrical Units	1 - 34
1.13.3 Thermal Units	1 - 35
1.13.4 Efficiency	1 - 37
1.14 Cells and Batteries	1 - 37
1.15 Types of Cells	1 - 38
1.16 Cell Terminology	1 - 39
1.17 Primary Cells	1 - 40
1.17.1 Dry Zinc-Carbon Cell	1 - 40
1.17.1.1 Cell Reaction	1 - 41
1.17.1.2 Features of Cell	1 - 41
1.17.1.3 Applications	1 - 41
1.17.2 Mercury Cell	1 - 42
1.17.2.1 Chemical reaction	1 - 42
1.17.2.2 Features of the cell	1 - 43
1.17.2.3 Applications	1 - 43
1.18 Secondary Cells	1 - 43
1.19 Lead Acid Battery	1 - 43
1.19.1 Functions of Separators	1 - 45
1.19.2 Chemical Action in Lead Acid Battery	1 - 45
1.19.3 Features of Lead Acid Battery	1 - 47
1.19.4 Conditions of a Fully Charged Battery	1 - 48
1.19.5 Maintenances and Precautions to be taken for Lead Acid Battery	1 - 48
1.19.6 Testing Procedure for Lead Acid Battery	1 - 49
1.19.7 Applications	1 - 50
1.20 Battery Capacity	1 - 50

1.21 Battery Efficiency	1 - 51
1.21.1 Ampere-hour Efficiency	1 - 51
1.21.2 Watt-hour Efficiency	1 - 51
1.22 Charge and Discharge Curves	1 - 52
1.23 Battery Charging	1 - 53
1.23.1 Indications of Fully Charged Battery	1 - 54
1.24 Charging Methods	1 - 54
1.24.1 Constant Current Method	1 - 54
1.24.2 Constant Voltage Method	1 - 55
1.24.3 Rectifier Method	1 - 56
1.25 Grouping of Cells	1 - 57
1.25.1 Series Grouping	1 - 57
1.25.2 Parallel Grouping	1 - 58
1.25.3 Series-Parallel Grouping	1 - 58
1.26 Alkaline Cells	1 - 59
1.27 Nickel - Iron Cell	1 - 59
1.27.1 Chemical Reaction	1 - 60
1.27.2 Electrical Characteristics	1 - 60
1.27.3 Capacity	1 - 61
1.27.4 Efficiency	1 - 61
1.27.5 Advantages	1 - 61
1.27.6 Disadvantages	1 - 62
1.27.7 Application	1 - 62
1.28 Nickel - Cadmium Cell	1 - 62
1.28.1 Chemical Reaction	1 - 63
1.28.2 Features	1 - 63
1.28.3 Applications	1 - 63
1.29 Comparison of Various Batteries	1 - 64
1.30 Comparison of Primary and Secondary Cells	1 - 64
1.31 NiMH Battery	1 - 65
1.31.1 Construction	1 - 65

1.31.2 Cell Reactions	1 - 66
1.31.3 Features	1 - 67
1.31.4 General Characteristics	1 - 67
1.31.5 Self Discharge Characteristics	1 - 67
1.31.6 Recharging Characteristics	1 - 69
1.31.7 Safety Precautions	1 - 69
1.31.8 Applications	1 - 70
1.31.9 Comparison	1 - 70
Examples with Solutions.....	1 - 71
Review Questions.....	1 - 101

Chapter - 2 D.C. Circuits (2 - 1) to (2 - 136)

2.1 Introduction.....	2 - 1
2.2 Network Terminology.....	2 - 1
2.2.1 Network	2 - 1
2.2.2 Network Element	2 - 1
2.2.3 Branch	2 - 2
2.2.4 Junction Point	2 - 2
2.2.5 Node	2 - 2
2.2.6 Mesh (or Loop)	2 - 2
2.3 Classification of Electrical Networks.....	2 - 2
2.4 Energy Sources	2 - 4
2.4.1 Voltage Source	2 - 4
2.4.2 Current Source	2 - 5
2.4.3 Dependent Sources	2 - 6
2.5 Ohm's Law.....	2 - 7
2.5.1 Limitations of Ohm's Law.....	2 - 8
2.6 Series Circuit.....	2 - 8
2.6.1 Characteristics of Series Circuits.....	2 - 9
2.7 Parallel Circuit.....	2 - 9
2.7.1 Characteristics of Parallel Circuits.....	2 - 10

Fundamentals of Electricity

1.1 Introduction

The study of an electrical engineering involves the analysis of the energy transfer from one form to another or from one point to another. So before beginning the actual study of an electrical engineering, it is necessary to discuss the fundamental ideas about the basic elements of an electrical engineering like electromotive force, current, resistance etc. The electricity is related with number of other types of systems like mechanical, thermal etc. There involves the transfer of different forms of energy into electrical or otherwise. To analyse such transfer, it is necessary to revise the S.I. units of measurement of different quantities like work, power, energy etc. in various systems.

This chapter explains the concept of basic electrical parameters alongwith the effect of temperature on resistance. The chapter involves the discussion of the characteristics of series and parallel circuits. At the end, the chapter includes the revision of units in different systems and their inter relations.

1.2 The Structure of Matter

In the understanding of fundamentals of electricity, the knowledge of the structure of matter plays an important role. The matter which occupies the space may be solid, liquid or gaseous. The molecules and atoms, of which all substances are composed are not at all elemental, but are themselves made up of simpler entities. We know this because we, up to certain extent, are successful in breaking atoms and studying the resulting products. For instance, such particles are obtained by causing ultraviolet light to fall on cold metal surfaces, such particles are spontaneously ejected from the radioactive elements. So these particles are obtained from many different substances under such widely varying conditions. It is believed that such particles are one of the elemental constituents of all matter, called electrons.

Infact, according to the modern electron theory, atom is composed of the three fundamental particles, which are invisible to bare eyes. These are the neutron, the proton and the electron. The proton is defined as positively charged while the electron is defined as negatively charged. The neutron is uncharged i.e. neutral in nature possessing no charge. The mass of neutron and proton is same while the electron is very light, almost

$1/1840$ th the mass of the neutron and proton. The following table gives information about these three particles.

Fundamental particles of matter	Symbol	Nature of charge possessed	Mass in kg.
Neutron	n	0	1.675×10^{-27}
Proton	p+	+	1.675×10^{-27}
Electron	e ⁻	-	9.107×10^{-31}

Table 1.1

1.2.1 Structure of an Atom

All of the protons and neutrons are bound together into a compact nucleus. Nucleus may be thought of as a central sun, about which electrons revolve in a particular fashion. This structure surrounding the nucleus is referred as the electron cloud.

In the normal atom the number of protons equal to the number of electrons. An atom as a whole is electrically neutral. The electrons are arranged in different orbits. The nucleus exerts a force of attraction on the revolving electrons and hold them together. All these different orbits are called shells and possess certain energy. Hence these are also called energy shells or quanta. The orbit which is closest to the nucleus is always under the tremendous force of attraction while the orbit which is farthest from the nucleus is under very weak force of attraction.

Key Point : *The electron or the electrons revolving in farthest orbit are hence loosely held to the nucleus. Such a shell is called the valence shell. And such electrons are called valence electrons.*

In some atoms such valence electrons are so loosely bound to the nucleus that at room temperature the additional energy imparted to the valence electrons causes them to escape from the shell and exist as free electrons. Such free electrons are basically responsible for the flow of electric current through metals.

Key Point : *More the number of free electrons, better is the metal for the conduction of the current. For example, copper has 8.5×10^{28} free electrons per cubic meter and hence it is a good conductor of electricity.*

The electrons which are revolving round the nucleus, not revolve in a single orbit. Each orbit consists of fixed number of electrons. In general, an orbit can contain a maximum of $2n^2$ electrons where n is the number of orbit. So first orbit or shell can occupy maximum of 2×1^2 i.e. 2 electrons while the second shell can occupy maximum of 2×2^2 i.e. 8 electrons and so on. The exception to this rule is that the valence shell can occupy maximum 8 electrons irrespective of its number. Let us see the structure of two different atoms.

1) **Hydrogen** : This atom consists of one proton and one electron revolving around the nucleus. This is the simplest atom. This is shown in the Fig. 1.1 (a). The dot represents an electron while nucleus is represented by a circle with the positive sign inside it.

2) **Silicon** : This atom consists of 14 electrons. These revolve around the nucleus in three orbits. The first orbit has maximum 2 electrons, the second has maximum 8 electrons and the third orbit has remaining 4 electrons. This is shown in the Fig. 1.1 (b).

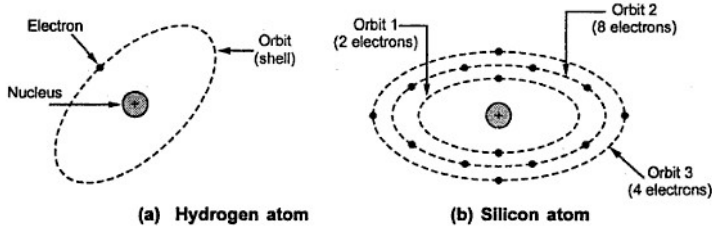

Fig. 1.1

The 4 electrons located in the farthest shell are loosely held by the nucleus and generally available as free electrons. If by any means some of the electrons are removed, the negative charge of that atom decreases while positively charged protons remain same. The resultant charge on the atom remains more positive in nature and such element is called **positively charged**. While if by any means the electrons are added, then the total negative charge increases than positive and such element is called **negatively charged**.

1.3 Concept of Charge

In all the atoms, there exists number of electrons which are very loosely bound to its nucleus. Such electrons are free to wander about, through the space under the influence of specific forces. Now when such electrons are removed from an atom it becomes positively charged. This is because of losing negatively charged particles i.e. electrons from it. As against this, if excess electrons are added to the atom it becomes negatively charged.

Key Point: Thus total deficiency or addition of excess electrons in an atom is called its charge and the element is said to be charged.

The following table shows the different particles and charge possessed by them.

Particle	Charge possessed in Coulomb	Nature
Neutron	0	Neutral
Proton	1.602×10^{-19}	Positive
Electron	1.602×10^{-19}	Negative

Table 1.2

1.3.1 Unit of Charge

As seen from the Table 1.2 that the charge possessed by the electron is very very small hence it is not convenient to take it as the unit of charge.

The unit of the measurement of the charge is Coulomb.

The charge on one electron is 1.602×10^{-19} , so one coulomb charge is defined as the charge possessed by total number of $(1 / 1.602 \times 10^{-19})$ electrons i.e. 6.24×10^{18} number of electrons.

Thus,

$$1 \text{ coulomb} = \text{charge on } 6.24 \times 10^{18} \text{ electrons}$$

From the above discussion it is clear that if an element has a positive charge of one coulomb then that element has a deficiency of 6.24×10^{18} number of electrons.

Key Point: Thus, addition or removal of electrons causes the change in the nature of the charge possessed by the element.

1.4 Concept of Electromotive Force and Current

It has been mentioned earlier that the free electrons are responsible for the flow of electric current. Let us see how it happens.

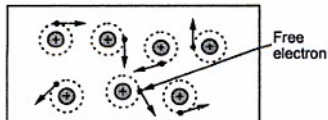

To understand this, first we will see the enlarged view of the inside of a piece of a conductor. A conductor is one which has abundant free electrons. The free electrons in such a conductor are always moving in random directions as shown in the Fig. 1.2.

Fig. 1.2 Inside the piece of a conductor

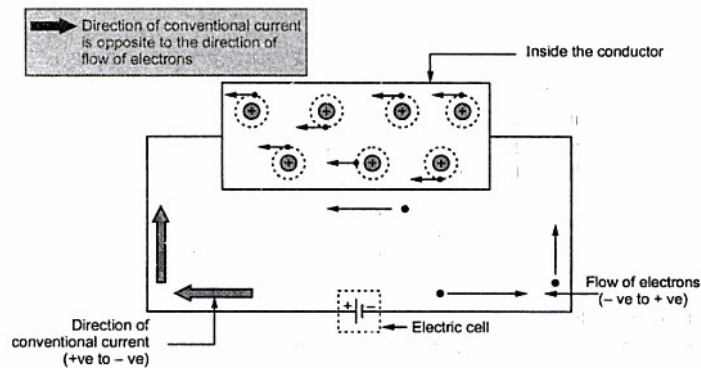

Fig. 1.3 The flow of current

The small electrical effort, externally applied to such conductor makes all such free electrons to drift along the metal in a definite particular direction. This direction depends on how the external electrical effort is applied to the conductor. Such an electrical effort may be an electrical cell, connected across the two ends of a conductor. Such physical phenomenon is represented in the Fig. 1.3.

Key Point: An electrical effort required to drift the free electrons in one particular direction, in a conductor is called *Electromotive Force (e.m.f.)*

The metal consists of particles which are charged. The like charges repel while unlike charges attract each other. But as external electric effort is applied, the free electrons as are negatively charged, get attracted by positive of the cell connected. And this is the reason why electrons get aligned in one particular direction under the influence of an electromotive force.

Key Point: The electric effort i.e. e.m.f. is maintained across the positive and negative electrodes of the cell, due to the chemical action inside the solution contained in the cell.

Atoms, when they loose or gain electrons, become charged accordingly and are called ions. Now when free electron gets dragged towards positive from an atom it becomes positively charged ion. Such positive ion drags a free electron from the next atom. This process repeats from atom to atom along the conductor. So there is flow of electrons from negative to positive of the cell, externally through the conductor across which the cell is connected. This movement of electrons is called an **Electric Current**.

The movement of electrons is always from negative to positive while movement of current is always assumed as from positive to negative. This is called **direction of conventional current**.

Key Point: Direction of conventional current is from positive to negative terminal while direction of flow of electrons is always from negative to positive terminal, through the external circuit across which the e.m.f. is applied.

We are going to follow direction of the conventional current throughout this book. i.e. from positive to negative terminal, of the battery through the external circuit.

1.5 Relation between Charge and Current

The current is flow of electrons. Thus current can be measured by measuring how many electrons are passing through material per second. This can be expressed in terms of the charge carried by those electrons in the material per second. So the **flow of charge per unit time** is used to quantify an electric current.

Key Point: So current can be defined as rate of flow of charge in an electric circuit or in any medium in which charges are subjected to an external electric field.

The charge is indicated by Q coulombs while current is indicated by I . The unit for the current is **Amperes** which is nothing but coulombs/sec. Hence mathematically we can write the relation between the charge (Q) and the electric current (I) as,

$$I = \frac{Q}{t} \text{ Amperes}$$

Where

I = average current flowing

Q = total charge transferred

t = time required for transfer of charge.

Definition of 1 Ampere : A current of 1 Ampere is said to be flowing in the conductor when a charge of one coulomb is passing any given point on it in one second.

Now 1 coulomb is 6.24×10^{18} number of electrons. So 1 ampere current flow means flow of 6.24×10^{18} electrons per second across a section taken any where in the circuit.

$$1 \text{ Ampere current} = \text{Flow of } 6.24 \times 10^{18} \text{ electrons per second}$$

1.6 Concept of Electric Potential and Potential Difference

When two similarly charged particles are brought near, they try to repel each other while dissimilar charges attract each other. This means, every charged particle has a tendency to do work.

Key Point: This ability of a charged particle to do the work is called its electric potential. The unit of electric potential is volt.

The electric potential at a point due to a charge is one volt if one joule of work is done in bringing a unit positive charge i.e. positive charge of one coulomb from infinity to that point.

Mathematically it is expressed as,

$$\text{Electrical Potential} = \frac{\text{Work done}}{\text{Charge}} = \frac{W}{Q}$$

Let us define now the potential difference.

It is well known that, flow of water is always from higher level to lower level, flow of heat is always from a body at higher temperature to a body at lower temperature. Such a level difference which causes flow of water, heat and so on, also exists in electric circuits. In electric circuits flow of current is always from higher electric potential to lower electric potential. So we can define potential difference as below :

Key Point: The difference between the electric potentials at any two given points in a circuit is known as Potential Difference (p.d.). This is also called voltage between the two points and measured in volts. The symbol for voltage is V .

For example, let the electric potential of a charged particle A is say V_1 while the electric potential of a charged particle B is say V_2 . Then the potential difference between the two particles A and B is $V_1 - V_2$. If $V_1 - V_2$ is positive we say that A is at higher potential than B while if $V_1 - V_2$ is negative we say that B is at higher potential than A.

Key Point: The potential difference between the two points is one volt if one joule of work is done in displacing unit charge (1 coulomb) from a point of lower potential to a point of higher potential.

Consider two points having potential difference of V volts between them, as shown in the Fig. 1.4. The point A is at higher potential than B. As per the definition of volt, the V joules of work is to be performed to move unit charge from point B to point A.

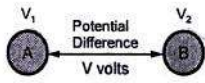

Fig. 1.4

Thus, when such two points, which are at different potentials are joined together with the help of wire, the electric current flows from higher potential to lower potential i.e. the electrons start flowing from lower potential to higher potential. Hence, to maintain the flow of electrons i.e. flow of electric current, there must exist a potential

difference between the two points.

Key Point: No current can flow if the potential difference between the two points is zero.

1.7 Electromotive Force and Potential Difference

Earlier we have seen the concept of e.m.f. The e.m.f. is that force which causes the flow of electrons i.e. flow of current in the given circuit. Let us understand its meaning more clearly.

Consider a simple cell shown in Fig. 1.5 (a). Due to the chemical reaction in the solution the terminal 'A' has acquired positive charge while terminal 'B' has acquired negative charge.

If now a piece of conductor is connected between the terminals A and B then flow of electrons starts through it. This is nothing but the flow of current through the conductor. This is shown in the Fig. 1.5 (b). The electrons will flow from terminal B to A and hence direction of current is from A to B i.e. positive to negative as shown.

One may think that once the positive charge on terminal A gets neutralised due to the electrons, then flow of electrons will stop. Both the terminals may get neutralised after some time. But this does not happen practically. This is because chemical reaction in the solution maintains terminal A positively charged and terminal B as negatively charged. This maintains the flow of current. The chemical reaction converts chemical energy into electric energy which maintains flow of electrons.

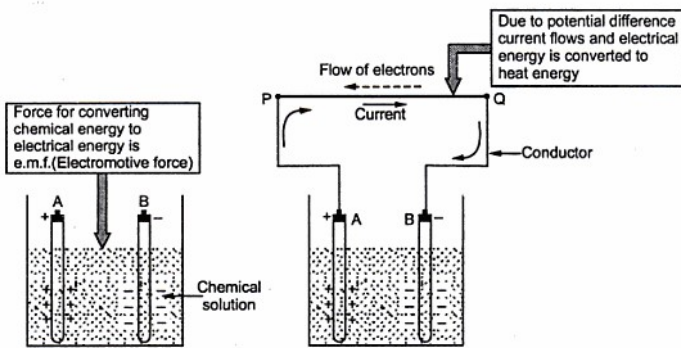

(a) Cell

Fig. 1.5

(b) Current due to a cell

Key Point: This force which requires to keep electrons in motion i.e. to convert chemical or any other form of energy into electric energy is known as Electromotive Force (e.m.f.) denoted by E . The unit of e.m.f. is volt and unless and until there is some e.m.f. present in the circuit, a continuous flow of current is not possible.

Consider two points P and Q as shown in the Fig. 1.5 (b), then the current is flowing from point P to point Q. This means there exists a potential difference between the points P and Q. This potential difference is called voltage denoted as V and measured in volts.

In other words we can explain the difference between e.m.f. and p.d. as below. In the cell two energy transformations are taking place simultaneously. The one is chemical energy because of solution in cell is getting converted to electrical energy which is basic cause for flow of electrons and hence current. The second is when current flows, the piece of metal gets heated up i.e. electrical energy is getting converted to heat energy, due to flow of current.

In the first transformation electrical energy is generated from other form of energy. The force involved in such transformation is electromotive force. When current flows, due to which metal gets heated up i.e. due to existence of potential difference between two points, voltage is existing. And in such case electrical energy gets converted to other form of energy. The force involved in such transformation is nothing but the potential difference or voltage. Both e.m.f. and potential difference are in generally referred as voltage.

1.8 Resistance

The current in the electrical circuit not only depends on e.m.f. or p.d. but also on the circuit parameters. For example if lamp is connected in a circuit, current gets affected and

lamp filament becomes hot radiating light. But if contact at one end is loose, current decreases but sparking occurs at loose contact making it hot. If two lamps are connected one after the other, brightness obtained is less than that obtained by a single lamp. These examples show that current, flow of electrons depends on the circuit parameters and not only the e.m.f. alone.

Key Point : *This property of an electric circuit tending to prevent the flow of current and at the same time causes electrical energy to be converted to heat is called resistance.*

The concept of resistance is analogous to the friction involved in the mechanical motion. Every metal has a tendency to oppose the flow of current. Higher the availability of the free electrons, lesser will be the opposition to the flow of current. The conductor due to the high number of free electrons offer less resistance to the flow of current. The opposition to the flow of current and conversion of electrical energy into heat energy can be explained with the help of atomic structure as below.

When the flow of electrons is established in the metal, the ions get formed which are charged particles as discussed earlier. Now free electrons are moving in specific direction when connected to external source of e.m.f. So such ions always become obstruction for the flowing electrons. So there is collision between ions and free flowing electrons. This not only reduces the speed of electrons but also produces the heat. The effect of this is nothing but the reduction of flow of current. Thus the material opposes the flow of current.

The resistance is denoted by the symbol 'R' and is measured in ohm symbolically represented as Ω . We can define unit ohm as below.

Key Point : *1 Ohm : The resistance of a circuit, in which a current of 1 Ampere generates the heat at the rate of one joules per second is said to be 1 ohm.*

Now

$$4.186 \text{ joules} = 1 \text{ calorie}$$

hence

$$1 \text{ joule} = 0.24 \text{ calorie}$$

Thus unit 1 ohm can be defined as that resistance of the circuit if it develops 0.24 calories of heat, when one ampere current flows through the circuit for one second.

Earlier we have seen that some materials possess large number of free electrons and hence offer less opposition to the flow of current. Such elements are classified as the 'Conductors' of electricity. While in some materials the number of free electrons are very less and hence offering a large resistance to the flow of current. Such elements are classified as the 'Insulators' of electricity.

Examples of good conductors are silver, copper, aluminium while examples of insulators are generally non metals like glass, rubber, wood, paper etc.

Let us see the factors affecting the resistance.

1.8.1 Factors Affecting the Resistance

1. Length of the material : The resistance of a material is directly proportional to the length. The resistance of longer wire is more. Length is denoted by 'l'.

2. Cross-sectional area : The resistance of a material is inversely proportional to the cross-sectional area of the material. More cross-sectional area allowed the passage of more number of free electrons, offering less resistance. The cross sectional area is denoted by 'a'.

3. The type and nature of the material : As discussed earlier whether it consists more number of free electrons or not, affects the value of the resistance. So material which is conductor has less resistance while an insulator has very high resistance.

4. Temperature : The temperature of the material affects the value of the resistance. Generally the resistance of the material increases as its temperature increases. Generally effect of small changes in temperature on the resistance is not considered as it is negligibly small.

So for a certain material at a certain temperature we can write a mathematical expression as,

$$R \propto \frac{l}{a}$$

and effect of nature of material is considered through the constant of proportionality denoted by ρ (rho) called resistivity or specific resistance of the material. So finally,

$$R = \frac{\rho l}{a}$$

Where

- l = length in metres
- a = cross-sectional area in square metres
- ρ = resistivity in ohms-metres
- R = resistance in ohms

1.9 Resistivity and Conductivity

The resistivity or specific resistance of a material depends on nature of material and denoted by ρ (rho). From the expression of resistance it can be expressed as,

$$\rho = \frac{Ra}{l} \quad \text{i.e.} \quad \frac{\Omega \cdot \text{m}^2}{\text{m}} \quad \text{i.e.} \quad \Omega \cdot \text{m}$$

It is measured in $\Omega \cdot \text{m}$.

Definition : The resistance of a material having unit length and unit cross-sectional area is known as its specific resistance or resistivity.

The Table 1.3 gives the value of resistivity of few common materials.

Name of material	ρ in $\Omega \cdot m$
International Standard Copper	1.72×10^{-8}
Aluminium Cast	2.6×10^{-8}
Bronze	3.6×10^{-8}
Iron-Wrought	10.7×10^{-8}
Carbon Graphite	4.6×10^{-8}
Gold	2.36×10^{-8}
Silver Annealed	1.58×10^{-8}
Lead	22×10^{-8}

Table 1.3

Key Point: A material with highest value of resistivity is the best insulator while with poorest value of resistivity is the best conductor.

1.9.1 Conductance (G)

The conductance of any material is reciprocal of its resistance and is denoted as G. It is the indication of ease with which current can flow through the material. It is measured in siemens.

So

$$G = \frac{1}{R} = \frac{a}{\rho l} = \frac{1}{\rho} \left(\frac{a}{l} \right) = \sigma \left(\frac{a}{l} \right)$$

1.9.2 Conductivity

The quantity $(1/\rho)$ is called conductivity, denoted as σ (sigma). Thus the conductivity is the reciprocal of resistivity. It is measured in siemens/ m.

Key Point: The material having highest value of conductivity is the best conductor while having poorest conductivity is the best insulator.

► **Example 1.1:** The resistance of copper wire 25 m long is found to be 50 Ω . If its diameter is 1mm, calculate the resistivity of copper.

Solution :

$$l = 25 \text{ m}, \quad d = 1 \text{ mm}, \quad R = 50 \Omega$$

$$a = \frac{\pi}{4} (d^2) = \frac{\pi}{4} (1^2) = 0.7853 \text{ mm}^2$$

$$\begin{aligned} \text{Now } \rho &= \frac{Ra}{l} = \frac{50 \times 0.7853 \times 10^{-6}}{25} \quad \dots 1 \text{ mm} = 10^{-3} \text{ m} \\ &= 1.57 \times 10^{-6} \Omega \cdot \text{m} = 1.57 \mu\Omega \cdot \text{m} \end{aligned}$$

►► **Example 1.2 :** Calculate the resistance of a 100 m length of wire having a uniform cross-sectional area of 0.02 mm^2 and having resistivity of $40 \mu\Omega \cdot \text{cm}$.

If the wire is drawn out to four times its original length, calculate its new resistance.

Solution : $l = 100 \text{ m}$, $a = 0.02 \text{ mm}^2$ and $\rho = 40 \mu\Omega \cdot \text{cm}$

$$\begin{aligned} \text{Now } R &= \frac{\rho l}{a} \quad \text{express } a \text{ in } \text{m}^2 \text{ and } \rho \text{ in } \Omega \cdot \text{m} \\ &= \frac{40 \times 10^{-6} \times 100}{0.02 \times 10^{-6}} = 2000 \Omega \end{aligned}$$

The wire is drawn out such that $l' = 4l$

But the volume of the wire must remain same before and after drawing the wire, which is the product of length and area.

$$\therefore \text{Volume} = a \times l = a' \times l'$$

$$\therefore a' = \frac{a \times l}{l'} = \frac{a \times l}{4l} = \frac{a}{4}$$

$$\begin{aligned} \therefore R' &= \text{new resistance} = \frac{\rho l'}{a'} = \frac{\rho(4l)}{\left(\frac{a}{4}\right)} \\ &= 16 \left(\frac{\rho l}{a}\right) = 16 R = 32000 \Omega \end{aligned}$$

►► **Example 1.3 :** A silver wire has a resistance of 2.5Ω . What will be the resistance of a manganin wire having a diameter, half of the silver wire and length one third? The specific resistance of manganin is 30 times that of silver.

Solution : $R_s = \text{silver resistance} = 2.5 \Omega$, $d_m = \text{manganin diameter} = \frac{d_s}{2}$

$$l_m = \text{manganin length} = \frac{l_s}{3}, \quad \rho_m = \text{manganin specific resistance} = 30 \rho_s$$

$$\text{Now } a_s = \frac{\pi}{4} (d_s)^2 = \text{area of cross-section for silver}$$

$$\therefore R_s = \frac{\rho_s l_s}{a_s} = \frac{\rho_s l_s}{\frac{\pi}{4}(d_s)^2} = 2.5 \Omega$$

$$\text{and } R_m = \frac{\rho_m l_m}{a_m} = \frac{30 \rho_s \times \left(\frac{l_s}{3}\right)}{\frac{\pi}{4}(d_m)^2} = \frac{10 \rho_s l_s}{\frac{\pi}{4}\left(\frac{d_s}{2}\right)^2}$$

$$= 40 \frac{\rho_s l_s}{\frac{\pi}{4}(d_s)^2} = 40 R_s = 100 \Omega \quad \dots \text{Resistance of manganin}$$

► **Example 1.4 :** Prove that the length 'l' and diameter 'd' of a cylinder of copper are

$$l = \left(\frac{rx}{\rho}\right)^{\frac{1}{2}} \text{ and } d = \left(\frac{16\rho r}{\pi^2 x}\right)^{\frac{1}{4}}$$

where x-volume, ρ -resistivity and r-resistance between opposite circular faces.

(May - 2001)

Solution : The resistance is given by,

$$r = \frac{\rho l}{a}$$

$$\text{Now } x = \text{volume} = a \times l$$

Multiplying numerator and denominator by l,

$$r = \frac{\rho l \times l}{a \times l} = \frac{\rho l^2}{x}$$

$$\therefore l = \left(\frac{rx}{\rho}\right)^{\frac{1}{2}} \quad \dots \text{proved}$$

$$\text{Now } a = \frac{\pi}{4} d^2$$

$$r = \frac{\rho l \times a}{a \times a} = \frac{\rho x}{a^2} \quad \dots \text{multiplying and dividing by } a$$

$$\therefore r = \frac{\rho x}{\left(\frac{\pi}{4} d^2\right)^2}$$

$$\therefore d^4 = \frac{16 \rho x}{\pi^2 r}$$

$$\therefore d = \left(\frac{16 \rho x}{\pi^2 r}\right)^{\frac{1}{4}} \quad \dots \text{proved}$$

1.10 Effect of Temperature on Resistance

The resistance of the material increases as temperature of a metal increases. Let us see the physical phenomenon involved in this process.

Atomic structure theory says that under normal temperature when the metal is subjected to potential difference, ions i.e. unmoving charged particles get formed inside the metal. The electrons which are moving randomly, get aligned in a particular direction as shown in the Fig. 1.6.

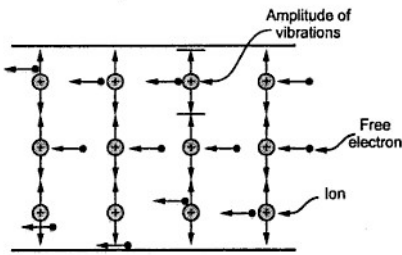

Fig. 1.6 Vibrating Ions in a conductor

At low temperatures, the ions are almost stationary. But as temperature increases, the ions gain energy and start oscillating about their mean position. Higher the temperature, greater is the amplitude. Such vibrating ions cause obstruction to the flowing electrons. Similarly due to high amplitude of oscillating ions, chances of collision of electrons are more. Due to collision and obstruction due to higher

amplitude of oscillations of ions, the resistance of material increases as temperature increases.

But this is not true for all materials. In some cases, the resistance decreases as temperature increases.

Key Point: So effect of temperature on the resistance depends on nature of material.

Let us see the effect of temperature on resistance of various category of materials.

1.10.1 Effect of Temperature on Metals

The resistance of all the pure metals like copper, iron, tungsten etc. increases linearly with temperature. For a copper, its resistance is $100\ \Omega$ at 0° then it increases linearly

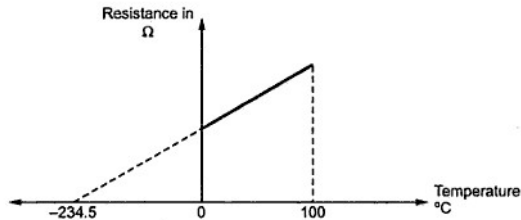

Fig. 1.7 Effect of temperature on metals

upto 100 °C. At a temperature of $- 234.5$ °C it is almost zero. Such variation is applicable to all the pure metals in the range of 0 °C to 100 °C. This is shown in the Fig. 1.7.

1.10.2 Effect of Temperature on Carbon and Insulators

The effect of temperature on carbon and insulators is exactly opposite to that of pure metals. Resistance of carbon and insulators decreases as the temperature increases. This can be explained with the help of atomic theory as below :

Insulators do not have enough number of free electrons and hence they are bad conductor of electricity. Now what happens in conductor is due to increase in temperature vibrations of ions increase but it does not increase number of free electrons. While in carbon and insulators due to increase in temperature, no doubt vibrations of ions increases but due to high temperature few electrons from atoms gain extra energy and made available as free electrons. So as number of free electrons increase though vibrations of ions increases overall difficulty to the flow of electrons reduces. This causes decrease in resistance.

Key Point: So in case of carbon and insulating materials like rubber, paper and all electrolytes, the resistance decreases as the temperature increases.

1.10.3 Effect of Temperature on Alloys

The resistance of alloys increases as the temperature increases but rate of increase is not significant. In fact the alloys like Manganin (alloy of copper, manganese and nickel), Eureka (alloy of copper and nickel) etc. show almost no change in resistance for considerable change in the temperature. Due to this property alloys are used to manufacture the resistance boxes.

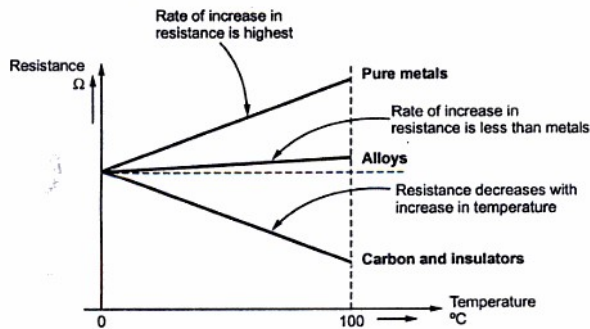

Some alloys show constant resistance characteristics

Fig. 1.8 (a) Effect of temperature on resistance

The Fig. 1.8 (a) shows the effect of temperature on metals, insulating materials and alloys.

The study of this, is very useful in finding out the temperature rise of cables, different windings in machines etc. Such study is possible by introducing the factor called resistance temperature coefficient of the material.

1.10.4 Effect of Temperature on Semiconductors

The materials having conductivity between that of metals and insulators are called semiconductors. The examples are silicon, germanium etc.

Key Point: Semiconductors have negative temperature coefficient of resistivity hence as temperature increases, their resistance decreases.

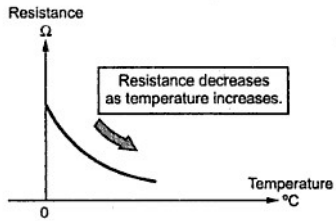

Fig. 1.8 (b) Effect of temperature on semiconductors

At normal temperature, the resistance of semiconductors is high. But as temperature increases, their resistance decreases with fast rate as shown in the Fig. 1.8(b). At absolute zero temperature, the semiconductors behave as perfect insulators. At higher temperature, more valence electrons acquire the energy and become free electrons. Due to increased number of free electrons, resistance of semiconductors decreases as temperature increases.

1.11 Resistance Temperature Coefficient (R.T.C.)

From the discussion uptill now we can conclude that the change in resistance is,

- 1) Directly proportional to the initial resistance.
- 2) Directly proportional to the change in temperature.
- 3) Depends on the nature of the material whether it is a conductor, alloy or insulator.

Let us consider a conductor, the resistance of which increases with temperature linearly

Let R_0 = Initial resistance at 0°C

R_1 = Resistance at $t_1^\circ\text{C}$

R_2 = Resistance at $t_2^\circ\text{C}$

As shown in the Fig. 1.9, $R_2 > R_1 > R_0$.

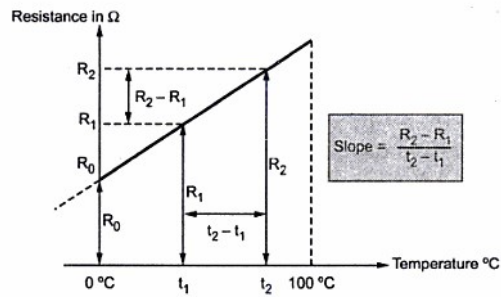

Fig. 1.9 Graph of resistance against temperature

Key Point: The change in resistance with temperature is according to the factor called resistance temperature coefficient (R.T.C.) denoted by α .

Definition of R.T.C.: The resistance temperature coefficient at t °C is the ratio of change in resistance per degree celcius to the resistance at t °C.

$$\text{R.T.C. at } t^{\circ}\text{C} = \frac{\Delta R \text{ per } ^{\circ}\text{C}}{R_t} = \alpha_t$$

From the Fig. 1.9, change in resistance = $R_2 - R_1$

change in temperature = $t_2 - t_1$

$$\therefore \text{change in resistance per } ^{\circ}\text{C} = \frac{\Delta R}{\Delta t} = \frac{R_2 - R_1}{t_2 - t_1}$$

Hence according to the definition of R.T.C. we can write α_1 i.e. R.T.C. at t_1 °C as,

$$\alpha_1 = \frac{\text{change in resistance per } ^{\circ}\text{C}}{\text{resistance at } t_1^{\circ}\text{C}} = \frac{(R_2 - R_1 / t_2 - t_1)}{R_1}$$

Similarly R.T.C. at 0 °C i.e. α_0 can be written as,

$$\alpha_0 = \frac{(R_1 - R_0 / t_1 - 0)}{R_0}$$

But $\frac{R_2 - R_1}{t_2 - t_1} = \frac{R_1 - R_0}{t_1 - 0} = \text{slope of the graph}$

Hence R.T.C. at any temperature t °C can be expressed as,

$$\alpha_t = \frac{\text{slope of the graph}}{R_t}$$

1.11.1 Unit of R.T.C.

$$\text{We know, } \alpha_t = \frac{\text{change in resistance per } ^\circ\text{C}}{\text{resistance at } t \text{ } ^\circ\text{C}} \Rightarrow \frac{\Omega / ^\circ\text{C}}{\Omega} \Rightarrow / ^\circ\text{C}$$

Thus unit of R.T.C. is per degree celcius i.e. / $^\circ\text{C}$

1.11.2 Use of R.T.C. in Calculating Resistance at t $^\circ\text{C}$

$$\text{Let } \alpha_0 = \text{R.T.C. at } 0 \text{ } ^\circ\text{C}$$

$$R_0 = \text{Resistance at } 0 \text{ } ^\circ\text{C}$$

$$R_1 = \text{Resistance at } t_1 \text{ } ^\circ\text{C}$$

$$\text{Then } \alpha_0 = \frac{(R_1 - R_0 / t_1 - 0)}{R_0} = \frac{R_1 - R_0}{t_1 R_0}$$

$$\therefore R_1 - R_0 = \alpha_0 t_1 R_0$$

$$\therefore R_1 = R_0 + \alpha_0 t_1 R_0 = R_0 (1 + \alpha_0 t_1)$$

Thus resistance at any temperature can be expressed as,

$$R_t = R_0 (1 + \alpha_0 t)$$

So knowing R_0 and α_0 at $0 \text{ } ^\circ\text{C}$, the resistance at any t $^\circ\text{C}$ can be obtained.

Alternatively this result can be expressed as below,

$$\text{Let } R_1 = \text{Resistance at } t_1 \text{ } ^\circ\text{C}$$

$$R_t = \text{Resistance at } t \text{ } ^\circ\text{C}$$

$$\alpha_1 = \frac{(R_t - R_1 / t - t_1)}{R_1}$$

... from definition

$$\therefore \alpha_1 R_1 (t - t_1) = R_t - R_1$$

$$\therefore R_t = R_1 [1 + \alpha_1 (t - t_1)]$$

Where $t - t_1 = \text{change in temperature} = \Delta t$

In general above result can be expressed as,

$$R_{\text{final}} = R_{\text{initial}} [1 + \alpha_{\text{initial}} (\Delta t)]$$

So if initial temperature is t_1 and final is t_2 , we can write,

$$R_2 = R_1 [1 + \alpha_1 \Delta t]$$

Key Point: Thus knowing resistance and R.T.C. of the material at any one temperature, the resistance of material at any other temperature can be obtained.

1.11.3 Effect of Temperature on R.T.C.

From the above discussion, it is clear that the value of R.T.C. also changes with the temperature. As the temperature increases, its value decreases. For any metal its value is maximum at 0 °C .

From the result of section 1.11.2 we can write,

$$R_2 = R_1 [1 + \alpha_1 (t_2 - t_1)] \quad \dots (1)$$

where R_1 and α_1 are resistance and R.T.C. at t_1 °C and R_2 is resistance at t_2 °C.

If the same resistance is cooled from t_2 to t_1 °C and if α_2 is R.T.C. at t_2 °C then,

$$R_1 = R_2 [1 + \alpha_2 (t_1 - t_2)] \quad \dots (2)$$

Dividing equation (1) by R_2 ,

$$\therefore 1 = \frac{R_1}{R_2} [1 + \alpha_1 (t_2 - t_1)]$$

$$\therefore \frac{R_2}{R_1} = 1 + \alpha_1 (t_2 - t_1) \quad \dots (3)$$

Dividing equation (2) by R_1 ,

$$1 = \frac{R_2}{R_1} [1 + \alpha_2 (t_1 - t_2)]$$

$$\therefore \frac{R_2}{R_1} = \frac{1}{1 + \alpha_2 (t_1 - t_2)} \quad \dots (4)$$

Equating (3) and (4) we can write,

$$1 + \alpha_1 (t_2 - t_1) = \frac{1}{1 + \alpha_2 (t_1 - t_2)}$$

$$\therefore \alpha_1 (t_2 - t_1) = \frac{1}{1 + \alpha_2 (t_1 - t_2)} - 1 = \frac{1 - 1 - \alpha_2 (t_1 - t_2)}{1 + \alpha_2 (t_1 - t_2)}$$

$$\therefore \alpha_1 (t_2 - t_1) = \frac{-\alpha_2 (t_1 - t_2)}{1 + \alpha_2 (t_1 - t_2)} = \frac{\alpha_2 (t_2 - t_1)}{1 + \alpha_2 (t_1 - t_2)}$$

$$\therefore \alpha_1 = \frac{\alpha_2}{1 + \alpha_2 (t_1 - t_2)} = \frac{1}{\frac{1}{\alpha_2} + (t_1 - t_2)}$$

$$\text{or } \alpha_2 = \frac{\alpha_1}{1 + \alpha_1 (t_2 - t_1)} = \frac{1}{\frac{1}{\alpha_1} + (t_2 - t_1)}$$

Using any of the above expression if α at any one temperature t_1 °C is known then α at any other temperature t_2 can be obtained.

If starting temperature is $t_1 = 0^\circ\text{C}$ and α at $t^\circ\text{C}$ i.e. α_t is required then we can write,

$$\alpha_t = \frac{\alpha_0}{1 + \alpha_0 (t - 0)} = \frac{\alpha_0}{1 + \alpha_0 t}$$

This is very useful expression to obtain R.T.C. at any temperature $t^\circ\text{C}$ from α_0 .

1.11.4 Effect of Temperature on Resistivity

Similar to the resistance, the specific resistance or resistivity also is a function of temperature. For pure metals it increases as temperature increases.

So similar to resistance temperature coefficient we can define temperature coefficient of resistivity as fractional change in resistivity per degree centigrade change in temperature from the given reference temperature.

i.e. if $\rho_1 =$ resistivity at $t_1^\circ\text{C}$

$\rho_2 =$ resistivity at $t_2^\circ\text{C}$

then temperature coefficient of resistivity at $t_1^\circ\text{C}$ can be defined as,

$$\alpha_{t1} = \frac{(\rho_2 - \rho_1)/(t_2 - t_1)}{\rho_1}$$

Similarly we can write the expression for resistivity at time $t^\circ\text{C}$ as,

$$\rho_t = \rho_0 (1 + \alpha_0 t)$$

$$\rho_{t2} = \rho_{t1} [1 + \alpha_{t1} (t_2 - t_1)]$$

►►► **Example 1.5 :** A certain winding made up of copper has a resistance of $100\ \Omega$ at room temperature. If resistance temperature coefficient of copper at 0°C is $0.00428/^\circ\text{C}$, calculate the winding resistance if temperature is increased to 50°C . Assume room temperature as 25°C .

Solution : $t_1 = 25^\circ\text{C}$, $R_1 = 100\ \Omega$, $t_2 = 50^\circ\text{C}$, $\alpha_0 = 0.00428/^\circ\text{C}$

Now $\alpha_t = \frac{\alpha_0}{1 + \alpha_0 t}$

$\therefore \alpha_1 = \frac{\alpha_0}{1 + \alpha_0 t_1} = \frac{0.00428}{1 + 0.00428 \times 25} = 0.003866/^\circ\text{C}$

Use $R_2 = R_1 [1 + \alpha_1 (t_2 - t_1)] = 100 [1 + 0.003866 (50 - 25)]$
 $= 109.6657\ \Omega$... Resistance at 50°C

►► **Example 1.6 :** The resistance of a wire increases from 40-ohm at 20 °C to 50 - ohm at 70 °C. Find the temperature co-efficient of resistance at 0 °C. (Dec. - 99, Dec. - 2000)

Solution : $R_1 = 40 \Omega$, $t_1 = 20 \text{ }^\circ\text{C}$, $R_2 = 50 \Omega$, $t_2 = 70 \text{ }^\circ\text{C}$

$$\text{Now, } R_2 = R_1 [1 + \alpha_1 \Delta t]$$

$$\therefore 50 = 40 [1 + \alpha_1 (70 - 20)] \text{ i.e. } \frac{5}{4} = 1 + \alpha_1 (50)$$

$$\therefore 50 \alpha_1 = 0.25$$

$$\therefore \alpha_1 = 5 \times 10^{-3} / ^\circ\text{C} \text{ i.e. at } t_1 = 20 \text{ }^\circ\text{C}$$

$$\text{Now, } \alpha_t = \frac{\alpha_0}{1 + \alpha_0 t} \text{ i.e. } \alpha_1 = \frac{\alpha_0}{1 + \alpha_0 t_1}$$

$$\therefore 5 \times 10^{-3} = \frac{\alpha_0}{1 + \alpha_0 \times 20} \text{ i.e. } 1 + 20 \alpha_0 = 200 \alpha_0$$

$$\therefore 180 \alpha_0 = 1$$

$$\therefore \alpha_0 = 5.55 \times 10^{-3} / ^\circ\text{C} \quad \dots \text{ Temperature coefficient at } 0 \text{ }^\circ\text{C}.$$

►► **Example 1.7 :** A specimen of copper has a resistivity (ρ) and a temperature coefficient of $1.6 \times 10^6 \text{ ohm-cm}$ at 0 °C and $1/254.5$ at 20 °C respectively. Find both of them at 60 °C. (May - 2001)

Solution : $\rho_0 = 1.6 \times 10^{-6} \Omega\text{-cm}$, $\alpha_1 = \frac{1}{254.5} / ^\circ\text{C}$ at 20 °C

$$\text{Now } \alpha_t = \frac{\alpha_0}{1 + \alpha_0 t}$$

$$\therefore \alpha_1 = \frac{\alpha_0}{1 + \alpha_0 \times 20}$$

$$\therefore \frac{1}{254.5} = \frac{\alpha_0}{1 + 20 \alpha_0}$$

$$\therefore 1 + 20 \alpha_0 = 254.5 \alpha_0$$

$$\therefore \alpha_0 = \frac{1}{234.5} / ^\circ\text{C} \text{ at } 0 \text{ }^\circ\text{C}$$

$$\therefore \alpha_{60} = \frac{\alpha_0}{1 + \alpha_0 \times 60} = \frac{1/234.5}{1 + \frac{60}{234.5}} = \frac{1}{294.5} / ^\circ\text{C} \quad \dots \text{ at } 60 \text{ }^\circ\text{C}$$

$$\rho_t = \rho_0 (1 + \alpha_0 t)$$

$$\therefore \rho_{60} = 1.6 \times 10^{-6} \left(1 + \frac{1}{234.5} \times 60 \right) = 2 \times 10^{-6} \Omega\text{-cm}$$

►► **Example 1.8 :** A resistance element having cross sectional area of 10 mm^2 and a length of 10 mtrs. takes a current of 4 A from a 220 V supply at ambient temperature of 20°C . Find out, i) the resistivity of the material and ii) current it will take when the temperature rises to 60°C . Assume $\alpha_{20} = 0.0003 /^\circ\text{C}$. (May - 2000)

Solution : $a = 10 \text{ mm}^2 = 10 \times 10^{-6} \text{ m}^2$, $V = 220 \text{ V}$, $l = 10 \text{ m}$, $I = 4 \text{ A}$, $t_1 = 20^\circ\text{C}$

and $\alpha_{20} = 0.0003 /^\circ\text{C}$, $R_1 = \frac{V}{I} = \frac{220}{4} = 55 \Omega$

Now, $R_1 = \frac{\rho_1 l}{a}$ i.e. $55 = \frac{\rho_1 \times 10}{10 \times 10^{-6}}$

$\therefore \rho_1 = 0.000055 \Omega - \text{m} = 55 \mu\Omega - \text{m}$... at 20°C

i) ρ_2 at $t_2 = 60^\circ\text{C}$, $\rho_2 = \rho_1 [1 + \alpha_1 (t_2 - t_1)]$
 $= 0.000055 [1 + 0.0003 (60 - 20)]$
 $= 55.66 \mu\Omega - \text{m}$

ii) $R_2 = \frac{\rho_2 l}{a}$
 $\therefore R_2 = \frac{55.66 \times 10^{-6} \times 10}{10 \times 10^{-6}} = 55.66 \Omega$

$\therefore I = \frac{V}{R_2} = \frac{220}{55.66} = 3.9525 \text{ A}$... at 60°C

►► **Example 1.9 :** A coil has a resistance of 18 ohm at 20°C and 22 ohm at 50°C . Find the rise in the temperature when resistance becomes 24 ohm . The room temperature is 18°C . (May-99, Dec-2007)

Solution : $R_1 = 18 \Omega$, $t_1 = 20^\circ\text{C}$, $R_2 = 22 \Omega$ and $t_2 = 50^\circ\text{C}$

Now, $R_2 = R_1 [1 + \alpha_1 (t_2 - t_1)]$ i.e. $22 = 18 [1 + \alpha_1 (50 - 20)]$

Solving, $\alpha_1 = 0.007407 /^\circ\text{C}$

Now $R_3 = 24 \Omega$ and $R_3 = R_1 [1 + \alpha_1 (t_3 - t_1)]$

$\therefore 24 = 18 [1 + 0.007407 (t_3 - 20)]$

$\therefore 0.3333 = 0.007407 (t_3 - 20)$

$\therefore t_3 - 20 = 45$

$\therefore t_3 = 65^\circ\text{C}$

So room temperature is 18°C given

\therefore Temperature rise = $65 - 18 = 47^\circ\text{C}$

1.11.5 R.T.C. of Composite Conductor

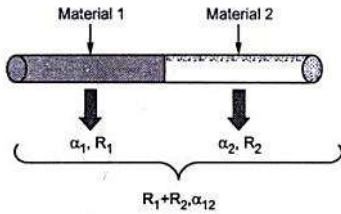

Fig. 1.10 Composite conductors

In many practical cases, it is necessary to manufacture conductors using two different types of materials, to achieve special requirements. Such a composite conductor is shown in the Fig. 1.10.

The material 1 has R.T.C. α_1 and its contribution in composite conductor is R_1 .

The material 2 has R.T.C. α_2 and its contribution in composite conductor is R_2 .

The combined composite conductor has resistance $R_1 + R_2$ while its RTC is neither α_1 nor α_2 but it is α_{12} , different than α_1 and α_2 .

Analysis of Composite conductor : The analysis includes the calculation of α_{12} from α_1 and α_2 .

- Let
- R_1 = Resistance of material 1 at t_1 °C
 - R_2 = Resistance of material 2 at t_1 °C
 - t_2 = New temperature attained by composite conductor
 - R_{1t} = Resistance of material 1 at t_2 °C
 - R_{2t} = Resistance of material 2 at t_2 °C
 - R_{12} = Resistance of composite material at t_1 °C
 - R_{12t} = Resistance composite material at t_2 °C

It is known that,

$$R_{1t} = R_1 [1 + \alpha_1 (t_2 - t_1)] \quad \dots(5)$$

$$R_{2t} = R_2 [1 + \alpha_2 (t_2 - t_1)] \quad \dots(6)$$

$$R_{12t} = R_{12} [1 + \alpha_{12} (t_2 - t_1)] \quad \dots(7)$$

Where α_{12} = R.T.C. of composite conductor at t_1 °C

Key Point : The overall circuit is series connection of resistances at all temperatures, from electrical point of view.

$$R_{12} = R_1 + R_2 \quad \dots \text{ at } t_1 \text{ °C} \quad \dots(8)$$

And $R_{12t} = R_{1t} + R_{2t} \quad \dots \text{ at } t_2 \text{ °C} \quad \dots(9)$

Using (8) and (9) in (7),

$$[R_{1t} + R_{2t}] = [R_1 + R_2] [1 + \alpha_{12} (t_2 - t_1)] \quad \dots(10)$$

Using (5) and (6) in (10),

$$R_1 [1 + \alpha_1 (t_2 - t_1)] + R_2 [1 + \alpha_2 (t_2 - t_1)] = [R_1 + R_2] [1 + \alpha_{12} (t_2 - t_1)]$$

$$\therefore R_1 + R_1 \alpha_1 (t_2 - t_1) + R_2 + R_2 \alpha_2 (t_2 - t_1) = R_1 + R_1 \alpha_{12} (t_2 - t_1) + R_2 + R_2 \alpha_{12} (t_2 - t_1)$$

Cancelling R_1 and R_2 from both sides,

$$R_1 \alpha_1 (t_2 - t_1) + R_2 \alpha_2 (t_2 - t_1) = R_1 \alpha_{12} (t_2 - t_1) + R_2 \alpha_{12} (t_2 - t_1)$$

Cancelling $(t_2 - t_1)$ from both sides,

$$\alpha_{12} (R_1 + R_2) = R_1 \alpha_1 + R_2 \alpha_2 = \alpha_{12} (R_1 + R_2) \quad \dots (11)$$

$$\therefore \alpha_{12} = \frac{R_1 \alpha_1 + R_2 \alpha_2}{R_1 + R_2} \quad \dots(12)$$

Thus α_{12} which is R.T.C. of composite conductor can be obtained at t_1 °C. Once this is known, α_{12} at any other temperature can be obtained as,

$$\alpha_{12t} = \frac{\alpha_{12}}{1 + \alpha_{12} \Delta t} \quad \text{where } \Delta t \text{ is temperature rise}$$

Prove that : $\frac{R_2}{R_1} = \frac{\alpha_1 - \alpha_{12}}{\alpha_{12} - \alpha_2}$

Divide the equation (11) by R_1 ,

$$\alpha_1 + \frac{R_2}{R_1} \alpha_2 = \alpha_{12} + \alpha_{12} \frac{R_2}{R_1}$$

$$\therefore \alpha_1 - \alpha_{12} = \left(\alpha_{12} \frac{R_2}{R_1} \right) - \left(\frac{R_2}{R_1} \alpha_2 \right)$$

$$\therefore \alpha_1 - \alpha_{12} = \frac{R_2}{R_1} [\alpha_{12} - \alpha_2]$$

$$\therefore \frac{R_2}{R_1} = \frac{\alpha_1 - \alpha_{12}}{\alpha_{12} - \alpha_2} \quad \dots \text{ Proved}$$

► **Example 1.10 :** At a particular temperature the two resistances are 60 Ω and 90 Ω having temperature coefficients of 0.0037 /°C and 0.005 /°C respectively. Calculate the temperature coefficient of composite conductor at the same temperature, obtained by combining above two resistances in series.

Solution : $R_1 = 60 \Omega$, $R_2 = 90 \Omega$, $\alpha_1 = 0.0037$ /°C, $\alpha_2 = 0.005$ /°C

Using the result derived,

$$\alpha_{12} = \frac{R_1 \alpha_1 + R_2 \alpha_2}{R_1 + R_2} = \frac{(60 \times 0.0037) + (90 \times 0.005)}{(60 + 90)} = 0.00448 \text{ /}^\circ\text{C}$$

►► **Example 1.11 :** Two coils A and B have resistances 60 Ω and 30 Ω respectively at 20 °C. The resistance temperature coefficients for the two coils at 20 °C are 0.001 /°C and 0.004 /°C. Find the resistance of their series combination at 50 °C.

Solution : The given values are,

$$\text{For coil A,} \quad R_{A1} = 60 \, \Omega, \quad t_1 = 20 \, ^\circ\text{C}, \quad \alpha_{A1} = 0.001 \, /^\circ\text{C}$$

$$\text{For coil B,} \quad R_{B1} = 30 \, \Omega, \quad t_1 = 20 \, ^\circ\text{C}, \quad \alpha_{B1} = 0.004 \, /^\circ\text{C}$$

$$\text{Now} \quad R_{A2} = R_{A1} [1 + \alpha_{A1}(t_2 - t_1)]$$

$$\therefore R_{A2} = 60 [1 + 0.001 (50 - 20)] = 61.8 \, \Omega$$

This is resistance of coil A at 50 °C.

$$\begin{aligned} \text{And} \quad R_{B2} &= R_{B1} [1 + \alpha_{B1} (t_2 - t_1)] \\ &= 30 [1 + 0.004 \times (50 - 20)] = 33.6 \, \Omega \end{aligned}$$

This is resistance of coil B at 50 °C.

$$\begin{aligned} \therefore \text{Resistance of their series combination at } 50 \, ^\circ\text{C} &= R_{A2} + R_{B2} = 61.8 + 33.6 \\ &= 95.4 \, \Omega \end{aligned}$$

►► **Example 1.12 :** Two coils A and B have resistances 100 Ω and 150 Ω respectively at 0 °C are connected in series. Coil A has resistance temperature coefficient of 0.0038 /°C while B has 0.0018 /°C. Find the resistance temperature coefficient of the series combination at 0 °C.

Solution : At 0 °C, the series combination is = $R_A + R_B = 100 + 150 = 250 \, \Omega$

$$\text{Now} \quad R_t = R_0 (1 + \alpha_0 t) \quad \text{i.e.} \quad (R_{AB})_t = (R_{AB})_0 [1 + \alpha_{AB0} t]$$

where R_{AB} is a resistance of series combination.

α_{AB} is resistance temperature coefficient of series combination.

$$\text{Now} \quad (R_A)_t = (R_A)_0 [1 + \alpha_{A0} t] \quad \text{and} \quad (R_B)_t = (R_B)_0 [1 + \alpha_{B0} t]$$

$$\therefore (R_{AB})_t = (R_A)_t + (R_B)_t = (R_A)_0 [1 + \alpha_{A0} t] + (R_B)_0 [1 + \alpha_{B0} t]$$

Substituting in above,

$$(R_A)_0 [1 + \alpha_{A0} t] + (R_B)_0 [1 + \alpha_{B0} t] = (R_{AB})_0 [1 + \alpha_{AB0} t]$$

$$(R_A)_0 = 100 \, \Omega, \quad \alpha_{A0} = 0.0038$$

$$(R_B)_0 = 150 \, \Omega, \quad \alpha_{B0} = 0.0018$$

$$(R_{AB})_0 = 250 \, \Omega$$

$$\therefore 100 [1 + 0.0038 t] + 150 [1 + 0.0018 t] = 250 [1 + (\alpha_{AB})_0 t]$$

$$\therefore 100 + 0.38t + 150 + 0.27t = 250 + 250 \alpha_{AB0} t$$

$$\therefore 0.65 t = 250 \alpha_{AB0} t$$

$$\therefore \alpha_{AB0} = 0.0026 / ^\circ\text{C}.$$

This is the resistance temperature coefficient of the series combination at 0 °C.

Note : The example may be solved using the result derived as,

$$\alpha_{AB} = \frac{R_A \alpha_A + R_B \alpha_B}{R_A + R_B} = 0.0026 / ^\circ\text{C}$$

But in examination, such examples must be solved using basic procedure as used above and not by using direct expression derived.

Example 1.13 : At any given temperature, two material A and B have resistance temperature coefficients of 0.004 and 0.0004 respectively. In what proportion resistances made up of A and B joined in series to give a combination having resistance temperature coefficient of 0.001 per °C ?

Solution : Let R be resistance of material A then (x R) be resistance of material B.

The resistance of the series combination is,

$$R_{AB} = R_A + R_B$$

$$R_{AB} = R + xR = (1 + x) R \Omega$$

Let (α_{AB}) = resistance temperature coefficient of the series combination.

Let there be t °C change in temperature so,

$$R'_{AB} = (R_{AB}) (\alpha_{AB}) (t) = (1 + x) R (0.001) (t) \quad \dots (1)$$

The resistance R'_{AB} is also $R'_A + R'_B$, where

R'_A is value of R_A due to change in temperature.

R'_B is value of R_B due to change in temperature.

$$R'_A = R_A \cdot (\alpha_A) (t) = R \cdot (0.004) (t)$$

$$\text{and } R'_B = R_B \cdot (\alpha_B) (t) = xR \cdot (0.0004) (t)$$

$$R'_{AB} = R (0.004) (t) + x R (0.0004) (t)$$

$$R'_{AB} = R t(0.004 + 0.0004 x) \quad \dots (2)$$

Equating 1 and 2,

$$\therefore R t (1 + x) (0.001) = R t (0.004 + 0.0004x)$$

$$0.001 + 0.001 x = 0.004 + 0.0004 x \quad \text{i.e. } 6 \times 10^{-4} x = 0.003$$

$$\therefore x = 5 \quad \text{i.e. } R_B = 5 R_A$$

i.e. resistance R_A and R_B must be joined in the proportion 1 : 5.

► **Example 1.14 :** A resistor of 80Ω resistance having a temperature coefficient of $0.0021 / ^\circ\text{C}$ at 0°C is to be constructed. Wires of two materials of suitable cross-sectional area are available. For material A the resistance is 80Ω per 100 m and temperature coefficient is $0.003 / ^\circ\text{C}$ at 0°C . For material B the corresponding figures are 60Ω per 100 m and $0.0015 / ^\circ\text{C}$ at 0°C . Calculate suitable lengths of the wires of materials A and B to be connected in series to get required resistor.

Solution : R_{A0} = Resistance of A at 0°C , R_{B0} = Resistance of B at 0°C

$$\alpha_{A0} = \text{R.T.C. of A at } 0^\circ\text{C} = 0.003 / ^\circ\text{C}, \quad \alpha_{B0} = \text{R.T.C. of B at } 0^\circ\text{C} = 0.0015 / ^\circ\text{C}$$

$$R_{AB0} = \text{Resistance of series combination of A and B at } 0^\circ\text{C} = 80 \Omega$$

$$\alpha_{AB0} = \text{R.T.C. of series combination at } 0^\circ\text{C} = 0.0021 / ^\circ\text{C}$$

$$\text{We know, } R_t = R_0 (1 + \alpha_0 t) \quad \text{i.e. } R_{At} = R_{A0}(1 + \alpha_{A0} t)$$

$$R_{Bt} = R_{B0} (1 + \alpha_{B0} t) \quad \text{and } R_{ABt} = R_{AB0} (1 + \alpha_{AB0} t)$$

$$\text{But } R_{ABt} = R_{At} + R_{Bt} \quad \dots \text{ series combination at } t^\circ\text{C}$$

$$\text{Similarly } R_{AB0} = R_{A0} + R_{B0} = 80 \Omega \quad \dots \text{ series combination at } 0^\circ\text{C}$$

$$\therefore R_{AB0} (1 + \alpha_{AB0} t) = R_{A0} (1 + \alpha_{A0} t) + R_{B0} (1 + \alpha_{B0} t)$$

$$\therefore 80 (1 + 0.0021 t) = R_{A0} (1 + 0.003 t) + R_{B0} (1 + 0.0015 t)$$

$$\therefore 80 + 0.168 t = R_{A0} + 0.003 R_{A0} t + R_{B0} + 0.0015 R_{B0} t$$

$$\therefore 80 + 0.168 t = (R_{A0} + R_{B0}) + 0.003 R_{A0} t + 0.0015 R_{B0} t$$

$$\text{Now } R_{A0} + R_{B0} = 80 \quad \text{and } R_{B0} = 80 - R_{A0}$$

$$\therefore 80 + 0.168 t = 80 + 0.003 R_{A0} t + 0.0015 (80 - R_{A0}) t$$

$$\therefore 0.168 t = [0.003 R_{A0} + 0.0015 (80 - R_{A0})] t$$

$$\therefore 0.168 = 0.003 R_{A0} + 0.12 - 0.0015 R_{A0}$$

$$\therefore R_{A0} = 32 \Omega$$

$$\therefore R_{B0} = 80 - 32 = 48 \Omega$$

Now material A resistance is 80Ω per 100 m so for 32Ω the length required is,

$$\frac{32}{80} \times 100 = 40 \text{ m}$$

The material B has resistance of 60Ω per 100 m so for 48Ω the length required is ,

$$\frac{48}{60} \times 100 = 80 \text{ m}$$

1.12 Insulation Resistance

The insulator is a material which offers a **very high resistance** to the flow of current. Because of this property such insulating materials are used to insulate current carrying conductors so that current do not leak from them and come in contact with other bodies.

The conductor with insulation around it is shown in the Fig. 1.11 (a) while leakage current path is shown in the Fig. 1.11 (b).

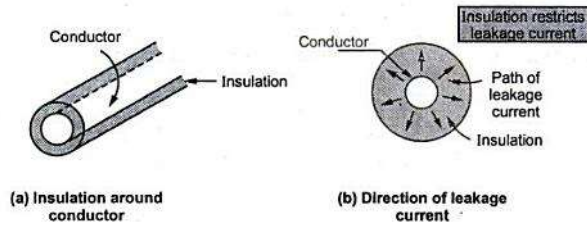

Fig. 1.11 Insulation and its function

Mainly such insulators are used to cover entire conductors which are required to be maintained at high potential with respect to earth. Such insulators try to avoid any leakage of current from conductors to earth. The resistance which offers opposition to the flow of leakage current is an ideal perfect insulation resistance. It stops the leakage current.

$$R_i = \frac{V}{I_l}$$

R_i = Insulation resistance, V = Voltage between conductor and earth, I_l = Leakage current.

Key Point: The value of insulation resistance is always very very high, of the order of megohms.

The commonly used insulating materials are rubber, paper, varnish, mica, porcelain, glass etc. In practice the cables which are used to carry heavy currents are insulated with the help of number of layers of insulating materials. Let us derive the expression for the insulation resistance of a cable.

1.12.1 Insulation Resistance of a Cable

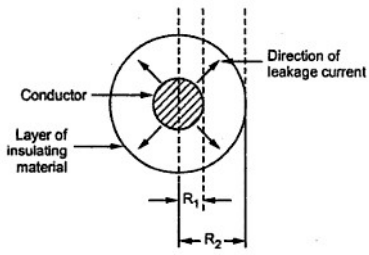

Fig. 1.12 Cable and path of leakage current

The Fig. 1.12 shows such a cable which is insulated with the help of layer of insulating material.

In such cables, leakage current flows radially from centre towards surface as shown in Fig. 1.12. Hence the cross-section of the path of such current is not constant but continuously changes with its length.

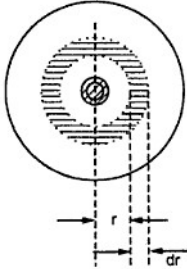

Fig. 1.13 Section of length dr

So to calculate its resistance, it is necessary to consider the section of cylindrical cable of radius r with small thickness as shown in the Fig. 1.13.

Let us find resistance of this ring. The radius of the ring is r and thickness dr. As leakage current flows radially the length in the direction of current, of this ring is dr only. While the total length of cable is say 'l' meters then its cross-sectional area perpendicular to the flow of current is surface area i.e. 2πrl.

Hence the resistance of this ring can be written as

$$d R_i = \rho \frac{dr}{2\pi r l} \quad \dots \text{ as } R = \frac{\rho l}{a}$$

$l = dr, \quad a = 2\pi r l, \quad \rho = \text{resistivity}$

The total insulation resistance can be obtained by integrating this from inner radius up to outer radius i.e. R₁ to R₂.

$$\begin{aligned} R_i &= \int_{R_1}^{R_2} d R_i = \int_{R_1}^{R_2} \frac{\rho dr}{2\pi r l} \\ &= \frac{\rho}{2\pi l} \int_{R_1}^{R_2} \frac{dr}{r} = \frac{\rho}{2\pi l} [\text{Log}_e r]_{R_1}^{R_2} \\ &= \frac{\rho}{2\pi l} [\text{Log}_e R_2 - \text{Log}_e R_1] \end{aligned}$$

$$\therefore R_1 = \frac{\rho}{2\pi l} \text{Log}_e \left(\frac{R_2}{R_1} \right) \Omega.$$

Thus insulation resistance is inversely proportional to its length.

Key Point: If two cables are joined in series, their conductor resistances come in series but their insulation resistances are in parallel while if two cables are connected in parallel then conductor resistances are in parallel but insulation resistances are in series.

► **Example 1.15:** A single core cable has a conductor of diameter 1.2 cm and its insulation thickness of 1.6 cm. The specific resistance of the insulating material is $7.5 \times 10^8 \text{ M}\Omega \text{ cm}$. Calculate the insulation resistance per kilometer of a cable. If now this resistance is to be increased by 20%. Calculate the thickness of the additional layer of insulation required.

Solution: Length $l = 1 \text{ km} = 1000 \text{ m}$

$$\begin{aligned} \rho &= 7.5 \times 10^8 \text{ M}\Omega\text{-cm} \\ &= 7.5 \times 10^8 \times 10^6 \Omega\text{-cm} \\ &= 7.5 \times 10^8 \times 10^6 \times 10^{-2} \Omega\text{-m} = 7.5 \times 10^{12} \Omega\text{-m} \end{aligned}$$

$$R_1 = \frac{D_1}{2} = \frac{1.2}{2} = 0.6 \text{ cm}$$

Insulation thickness = 1.6 cm

$$\therefore R_2 = R_1 + t = 2.2 \text{ cm}$$

$$\begin{aligned} R_1 &= \frac{\rho}{2\pi l} \text{Log}_e \left(\frac{R_2}{R_1} \right) = \frac{7.5 \times 10^{12}}{2\pi \times 1000} \text{Log}_e \left(\frac{2.2}{0.6} \right) \\ &= 1550.9 \text{ M}\Omega \end{aligned}$$

New R_1 required is,

$$\begin{aligned} &= 1550.9 + 0.2 \times 1550.9 \text{ (increased by 20 \%)} \\ &= 1861.08 \text{ M}\Omega \end{aligned}$$

$$\therefore 1861.08 \times 10^6 = \frac{\rho}{2\pi l} \text{Log}_e \left(\frac{R'_2}{R_1} \right)$$

$$\therefore 1861.08 \times 10^6 = \frac{7.5 \times 10^{12}}{2\pi \times 1000} \text{Log}_e \left(\frac{R'_2}{0.6} \right)$$

$$\therefore R'_2 = 2.8528 \text{ cm} = \text{New outermost radius.}$$

$$\begin{aligned} \therefore \text{Additional thickness required} &= 2.8528 - R_1 - (\text{original thickness}) \\ &= 2.8528 - 0.6 - 1.6 = 0.6528 \text{ cm} \end{aligned}$$

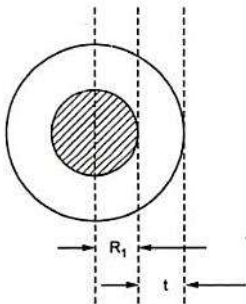

Fig. 1.14

►► **Example 1.16 :** Two underground cables A and B, each has a conductor resistance of 0.6Ω and 0.8Ω respectively. Each has a insulation resistance of $600 M\Omega$ and $400 M\Omega$ respectively. If the cables are connected in,

i) Series and ii) Parallel,

Calculate conductor resistance, and insulation resistance of the combination.

Solution : i) Cables are in series

Conductor resistances are also in series.

$$\therefore \text{Conductor resistance of combination} = 0.6 + 0.8 = 1.4 \Omega$$

While insulation resistance are in parallel under series connection.

$$\begin{aligned} \therefore R_i \text{ of combination} &= \frac{R_A \times R_B}{R_A + R_B} = \frac{600 \times 10^6 \times 400 \times 10^6}{600 \times 10^6 + 400 \times 10^6} \\ &= 240 M\Omega \end{aligned}$$

ii) Cables are in parallel

Conductor resistances are also in parallel.

$$\therefore \text{Combinational conductor resistance} = \frac{0.6 \times 0.8}{0.6 + 0.8} = 0.3428 \Omega$$

While insulation resistances are in series when cables are in parallel.

$$\therefore R_i \text{ of combination} = R_A + R_B = 400 + 600 = 1000 M\Omega$$

1.12.2 Effect of Temperature on Insulation Resistance

The insulation resistance depends on the temperature. When temperature increases, the valence electrons which are loosely bound to the nucleus, acquire thermal energy. Due to the additional energy acquired, these valence electrons become completely free from the force of attraction by the nucleus. These electrons are available as the free electrons.

Key Point: More the number of free electrons, better is the conductivity and less is the resistivity.

Hence as temperature increases, the insulation resistance decreases while conductivity increases.

The effect can be mathematically expressed in terms of an exponential relationship as,

$$R_{it} = R_{i0} e^{-\alpha_0 t}$$

Where

R_{it} = Insulation resistance at $t^\circ\text{C}$

R_{i0} = Insulation resistance at 0°C

α_0 = R.T.C. at 0°C

1.12.3 Effect of Moisture on Insulation Resistance

Practically insulation covering the conductor may absorb some moisture. Now water is very good conductor of electricity hence possibility of conduction increases through the insulation when it absorbs water. Thus moisture provides path for the leakage current.

Key Point: As moisture content in insulation increases, the insulation resistance decreases as the water absorbed allows the leakage current to flow through it easily.

1.13 Fundamental Quantities and Units

Scientists and engineers know that the terms they use, the quantities they measure must all be defined precisely. Such precise and standard measurements can be specified only if there is common system of indication of such measurements. This common system of units is called 'SI' system i.e. International System of Units.

The S.I. system is divided into seven base units and two supplementary units. The seven fundamental or base units are length, mass, time, electric current, temperature, amount of substance and luminous intensity. The two supplementary units are plane angle and solid angle. All other units are derived which are obtained from the above two classes of units. The derived units are classified into three main groups,

1. Mechanical units
2. Electrical units
3. Heat units

Let us discuss these groups in detail.

1.13.1 Mechanical Units

The various mechanical units are,

1. **Mass** : It is the matter possessed by the body. It is measured in kg and denoted as m.
2. **Velocity** : It is the distance travelled per unit time, measured in m/s.
3. **Acceleration** : It is the rate of change of velocity, measured in m/s^2 .
4. **Force** : It is the push or pull which changes or tends to change the state of rest or uniform motion of body, measured in Newton.

One newton is the force required to give an acceleration of $1 m/s^2$ to a mass of 1 kg.

$$F = m \times a \quad N$$

5. **Weight** : The gravitational force exerted by the earth on a body is called its weight, measured in Newtons.

$$\text{Weight} = m \times g \quad \text{where } g = \text{gravitational acceleration} = 9.81 m/s^2$$

6. **Torque** : It is the product of a force and a perpendicular distance from the line of action of force to the axis of rotation. It is measured in Nm.

$$T = F \times r \quad \text{Where } r = \text{radial distance of rotation}$$

7. Work : The work is said to be done when force acting on a body causes it to move. If body moves through distance d under the force F then,

$$W = F \times d$$

The work is measured in Joules.

8. Energy : It is the capacity to do the work. The work is done always at the cost of energy. The unit of energy is also Joules. The two forms of an energy are,

i) **Kinetic energy** which is the energy possessed by a body due to its motion. If body of mass m is moving with velocity v then the kinetic energy is,

$$\text{K.E.} = \frac{1}{2} m v^2 \text{ J}$$

ii) **Potential energy** which is the energy possessed by a body due to its position. When a body of mass m is lifted vertically through height of h then the potential energy is,

$$\text{P.E.} = mgh = Wh \text{ J} \quad \text{where } W = \text{weight}$$

9. Power : The rate of doing work is power measured in J/sec i.e. watts

$$P = \frac{\text{work done}}{\text{time}} \text{ J/sec i.e. W}$$

and

$$1 \text{ W} = 1 \text{ J/sec}$$

Energy expended = Power \times time = work done

1.13.1.1 Relation between Torque and Power

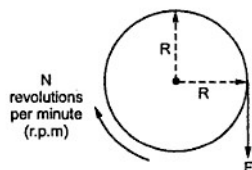

Fig. 1.15

Consider a pulley of radius R and F is the force applied as shown in the Fig. 1.15.

$$T = F \times R \text{ Nm}$$

Let speed of pulley is N revolutions per minute. Now work done in one revolution is force into distance travelled in one revolution.

$$\begin{aligned} d &= \text{distance travelled in 1 revolution} \\ &= 2 \pi R \end{aligned}$$

$$\therefore W = \text{work done in 1 revolution} = F \times d = 2 \pi R F \text{ J}$$

The time required for a revolution can be obtained from speed N r.p.m.

$$t = \text{time for a revolution} = \frac{60}{N} \text{ sec}$$

$$\therefore P = \text{power} = \frac{W}{t} = \frac{2\pi R F}{\frac{60}{N}} = \left(\frac{2\pi N}{60}\right) \times (F \times R)$$

$$\therefore \boxed{P = T \times \omega}$$

Where $T = F \times R = \text{torque in Nm}$

$$\omega = \frac{2\pi N}{60} = \text{angular velocity in rad/sec}$$

The relation $P = T \omega$ is very important in analysing various mechanical systems.

1.13.2 Electrical Units

The various electrical units are,

1. Electrical work : In an electric circuit, movement of electrons i.e. transfer of charge is an electric current. The electrical work is done when there is a transfer of charge. The unit of such work is Joule.

Key Point: One joule of electrical work done is that work done in moving a charge of 1 coulomb through a potential difference of 1 volt.

So if V is potential difference in volts and Q is charge in coulombs then we can write,

$$\text{Electrical work } W = V \times Q \text{ J} \quad \text{But } I = \frac{Q}{t}$$

$$\therefore \boxed{W = VIt \text{ J}} \quad \text{Where } t = \text{Time in seconds}$$

2. Electrical power : The rate at which electrical work is done in an electric circuit is called an electrical power.

$$\text{Electrical power } P = \frac{\text{electrical work}}{\text{time}} = \frac{W}{t} = \frac{VIt}{t}$$

$$\therefore \boxed{P = VI \text{ J/sec i.e. watts}}$$

Thus power consumed in an electric circuit is 1 watt if the potential difference of 1 volt applied across the circuit causes 1 ampere current to flow through it.

Remember, $1 \text{ watt} = 1 \text{ joule/sec}$

As unit of power watt is small, many a times power is expressed as kW (1000 watts) or MW (1×10^6 watts).

According to Ohm's law, $V = IR$ or $I = V/R$

Using this, power can be expressed as,

$$P = VI = I^2R = \frac{V^2}{R} \quad \text{Where } R = \text{Resistance in } \Omega$$

3. Electrical energy : An electrical energy is the total amount of electrical work done in an electric circuit.

$$\therefore \text{Electrical energy } E = \text{Power} \times \text{Time} = VIt \quad \text{joules}$$

The unit of energy is joules or watt-sec.

The energy consumed by an electric circuit is said to be 1 joule or watt-sec when it utilises power of 1 watt for 1 second.

As watt-sec unit is very small, the electrical energy is measured in bigger units as watt-hour (Wh) and kilo watt-hour (kWh).

$$1 \text{ Wh} = 1 \text{ watt} \times 1 \text{ hour} = 1 \text{ watt} \times 3600 \text{ sec} = 3600 \text{ watt-sec i.e. J}$$

$$\text{and } 1 \text{ kWh} = 1000 \text{ Wh} = 1 \times 10^3 \times 3600 \text{ J} = 3.6 \times 10^6 \text{ J}$$

When a power of 1 kW is utilised for 1 hour the energy consumed is said to be 1 kWh. This unit is called **Board of Trade Unit**.

Key point *The electricity bills we are getting are charged based on this commercial unit of energy i.e. kWh or unit.*

1.13.3 Thermal Units

1. Heat energy : The flow of current through a material produces a heat. According to the principle of conservation of energy, the electrical energy spent must be equal to the heat energy produced. This is called **Joule's law**.

$$\text{Heat energy } H = VIt = I^2 R t = \frac{V^2}{R} t \quad \text{joules}$$

2. Specific heat capacity : The quantity of heat required to change the temperature of 1 kilogram of substance through 1 degree kelvin is called specific heat of that substance.

Key Point: *Its unit is Joules/kg - °K. This is denoted by 'C'*

$$C = \frac{Q}{m\Delta T} = \frac{Q}{m(T_2 - T_1)}$$

Following table gives the values of specific heat capacity of various substances.

Substance	Specific heat capacity in J/kg - °K
Water	4187
Copper	390
Aluminium	950
Iron	500

Table 1.4

3. Sensible heat : The quantity of heat gained or lost when change in temperature occurs is called sensible heat. This can be calculated as,

$$\text{Sensible heat} = m C \Delta t \text{ Joules.}$$

m = Mass of substance in kg

C = Specific heat in J/kg -°K

Δt = $t_2 - t_1$ = change in temperature

4. Latent heat : The quantity of heat required to change the state of the substance i.e. solid to liquid to gas without change in its temperature is called latent heat.

It can be calculated as,

$$\text{Latent Heat} = m \times L \text{ Joules.}$$

Where m = Mass of substance in kg

L = Specific latent heat or specific enthalpy

The unit of L is J/kg while unit of latent heat is joules.

$$\text{Total heat} = \text{Sensible heat} + \text{Latent heat}$$

The various relations between electrical and thermal units are,

$$1 \text{ calorie} = 4.186 \text{ joules}$$

$$1 \text{ joule} = \frac{1}{4.186} \text{ calorie}$$

$$= 0.2389 \text{ calorie}$$

$$1 \text{ kWh} = 3.6 \times 10^6 \text{ J} = 860 \text{ k cal}$$

5. Specific enthalpy : It is the heat required to change the state of one kilogram mass of a substance without change in temperature.

Its unit is J/kg.

6. Calorific value : Heat energy can be produced by burning the fuels. The calorific value of a fuel is defined as the amount of heat produced by completely burning unit mass of that fuel.

It is measured in kJ/gram, kJ/kg etc.

$$\text{Heat produced in joules} = \text{Mass in kg} \times \text{calorific value in J/kg}$$

7. Water equivalent of container : When water is heated in a container then the container is also heated. So heat is wasted to heat the container. To take into account this heat, water equivalent of container must be known.

Key Point : The water equivalent of container means whatever heat is required to heat body of container can be considered to be equivalent to heat energy required to heat equivalent mass of water.

This is shown in the Fig. 1.16.

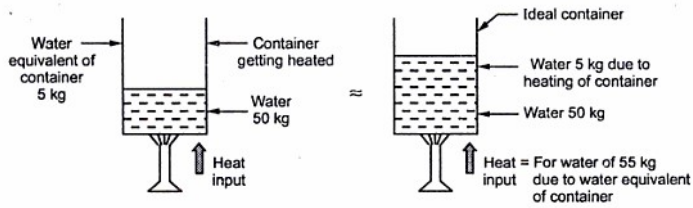

Fig. 1.16 Concept of water equivalent

1.13.4 Efficiency

The efficiency can be defined as the ratio of energy output to energy input. It can also be expressed as ratio of power output to power input.

Its value is always less than 1. Higher its value, more efficient is the system of equipment. Generally expressed in percentage. Its symbol is η .

$$\begin{aligned} \% \eta &= \frac{\text{Energy output}}{\text{Energy input}} \times 100 \\ &= \frac{\text{Power output}}{\text{Power input}} \times 100 \end{aligned}$$

1.14 Cells and Batteries

A device which is used as a source of e.m.f. and which works on the principle of conversion of chemical energy into an electrical energy, is called a cell. But practically the voltage of a single cell is not sufficient to use in any practical application. Hence various

cells are connected in series or parallel to obtain the required voltage level. The combination of various cells, to obtain the desired voltage level is called a battery.

The conductors of electricity can be classified in two categories as,

1. **Non electrolytes** : Conductors which are not affected by the flow of current through them are nonelectrolytes. The examples are metals, alloys, carbon and some other materials.
2. **Electrolytes** : Conductors which undergo decomposition due to the flow of current through them are electrolytes. The examples are various acids, bases, salt solutions and molten salts.

In any cell, two different conducting materials are immersed in an electrolyte. The chemical reaction results which separates the charges forming a new solution. The charges get accumulated on the conductors. Such charged conductors are called **electrodes**. The positively charged conductor is called **anode** while the negatively charged conductor is called **cathode**. Thus the charge accumulated on the electrodes creates a potential difference between the two conductors. The conductor ends are brought out as the terminals of the cell, for connecting the cell to an external circuit. The terminals are marked as positive and negative. Thus the chemical energy gets converted to an electrical energy. Hence the cell is an electrochemical device.

Key Point : The chemical action in the cell continuously separates the charges to maintain the required terminal voltage.

1.15 Types of Cells

The two types of cells are,

1. **Primary Cells** : The chemical action in such cells is not reversible and hence the entire cell is required to be replaced by a new one if the cell is down. The primary cells can produce only a limited amount of energy. Mostly the nonelectrolytes are used for the primary cells. The various examples of primary cells are zinc-carbon dry cell, zinc chloride cell, alkaline cells, mercury cell etc.
2. **Secondary Cells** : The chemical action in such cells is reversible. Thus if cell is down, it can be charged to regain its original state, by using one of the charging methods. In charging, the electrical energy is injected to the cell by passing a current in the opposite direction through it. In such cells, the electrical energy is stored in the form of chemical energy and the secondary cells are also called **storage cells, accumulators or rechargeable cells**. These are used to produce large amount of energy. The various types of secondary cells are Lead-acid cell, Nickel-cadmium alkaline cell etc. The most commonly used secondary cell is a Lead-acid cell or Lead-acid battery.

1.16 Cell Terminology

The various terminologies related to a cell are,

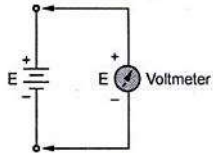

Fig. 1.17 E.M.F of a cell

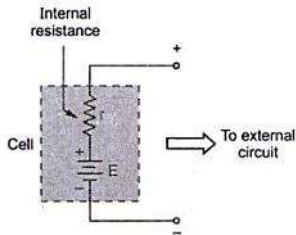

Fig. 1.18 Symbol of a cell

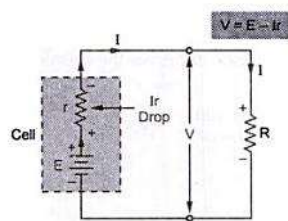

Fig. 1.19 Terminal voltage

Mathematically, the terminal voltage is given by,

$$V = E - Ir$$

From external resistance side we can write,

$$V = IR$$

1. **E.M.F. of a cell** : The voltage of a cell in an open circuit condition, measured by a very high resistance voltmeter is called e.m.f. of a cell. This is denoted as E , measured in volts. This is shown in the Fig. 1.17.

2. **Internal resistance of a cell** : The cell completes path of current from its positive terminal to negative terminal through **external circuit**. But to complete the closed path, the current flows from negative to positive terminal of cell, **internally**. The opposition by a cell to a current, when it flows internal to the cell is called the **internal resistance** of the cell. It is denoted as r and measured in ohms.

In an equivalent circuit of a cell, its internal resistance is shown in series with that cell. The Fig. 1.18 shows a cell and its internal resistance.

3. **Terminal voltage** : When an external resistance is connected across the terminals of the cell, the current I flows through the circuit. There is voltage drop ' Ir ' across the internal resistance of the cell. The cell e.m.f. E has to supply this drop. Hence practically the voltage available at the terminals of the cell is less than E by the amount equal to ' Ir '. This voltage is called the **terminal voltage** V . This is shown in the Fig. 1.19.

Key Point: Practically internal resistance of the cell must be as small as possible.

It can also be observed that on no load i.e. external resistance not connected, the open circuit terminal voltage is same as e.m.f. of the cell, as current $I = 0$.

$$\therefore V = E \quad \dots \text{ on no load i.e. open circuit}$$

1.17 Primary Cells

It is seen that the primary cell is that which is required to replace by new one when it is run down.

The oldest types of primary cell are simple voltaic cell, Daniell cell, Leclanche cell etc. Some commonly used primary cells are,

1. Dry cell [Zinc-Carbon]
2. Mercury cell
3. Zinc-Chloride cell
4. Lithium cell
5. Alkaline Zinc-mercury oxide cell

Let us discuss primary cell in detail.

1.17.1 Dry Zinc-Carbon Cell

This is most common type of dry cell. It is the type of Leclanche cell.

Negative electrode → Zinc cup lined with paper
Positive electrode → Centrally located carbon rod

The space between the paper and carbon rod is filled with a paste of sal ammoniac, zinc chloride, manganese dioxide and carbon dust.

Key Point: *The paste is not dry and if it becomes dry, the cell becomes useless.*

The sal ammoniac acts as an electrolyte, the zinc chloride improves the chemical action and manganese dioxide acts as depolariser.

The Fig. 1.20 shows the cross-section of zinc-carbon dry cell.

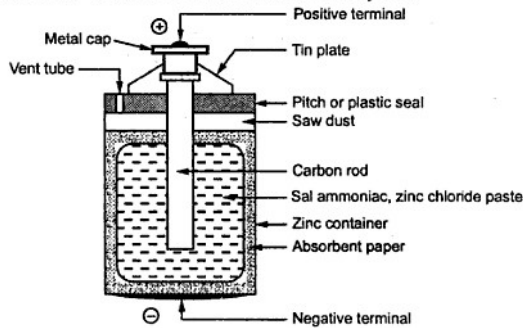

Fig. 1.20 Zinc-carbon dry cell

The zinc container is lined with paper to avoid direct reaction of zinc with carbon. The container is sealed with an insulator called pitch which is plastic seal of the cell. The tin plates are used at top and bottom which are positive and negative terminals of the cell respectively. The carbon dust added to the paste used to improve the conduction of the electrolyte. Externally the zinc container is covered with cardboard jacket to avoid any type of leakage.

1.17.1.1 Cell Reaction

When zinc atoms react with the electrolyte, the electrons are removed from the carbon rod. These electrons accumulate on the zinc electrode. As the electrons are negatively charged, the zinc electrode acts as negative terminal. The carbon rod from where negative charge is lost in the form of electrons, acts as positive terminal.

The sal ammoniac i.e. ammonium chloride paste reacts with zinc to liberate hydrogen.

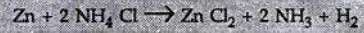

The hydrogen reacts with manganese dioxide as,

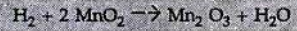

Key Point : Hydrogen is liberated at faster rate while reaction of MnO₂ is slow. Due to this, hydrogen accumulates in the form of thin layer on carbon rod. This is called polarisation. Due to this, cell e.m.f. goes down if cell is operated for longer time.

1.17.1.2 Features of Cell

1. The e.m.f. of new dry cell is about 1.5 V.
2. The internal resistance is about 0.1 to 0.4 Ω.
3. The capacity of 32 Ah when discharged through 20 Ω resistor till voltage drops to 0.5 V.
4. When not in use for long time, zinc gets attacked by the paste slowly and cell becomes useless though not in use.
5. In working condition, voltage drops due to polarisation hence used for intermittent service. When disconnected the depolarisation occurs to restore the cell e.m.f.
6. Least expensive.
7. Portable and convenient to use.

1.17.1.3 Applications

Mostly used to get intermittent service to avoid polarisation. The various applications are,

- | | |
|----------------------------------|------------------------------------|
| 1. Torch lights | 2. Telephone and telegraph systems |
| 3. Electronic apparatus and toys | 4. Wall clocks |

5. Electric bells
6. Radio receivers and many other consumer applications

1.17.2 Mercury Cell

This is another type of a primary cell

Negative electrode →	Zinc cylinder
Positive electrode →	Mercury compound in contact with nickel plated steel or stainless steel

The concentrated solution of potassium hydroxide (KOH) and zinc oxide (ZnO) is used as an electrolyte.

It is available in cylindrical shape or miniature button shape.

The Fig. 1.21 shows the construction of a cylindrical mercury cell.

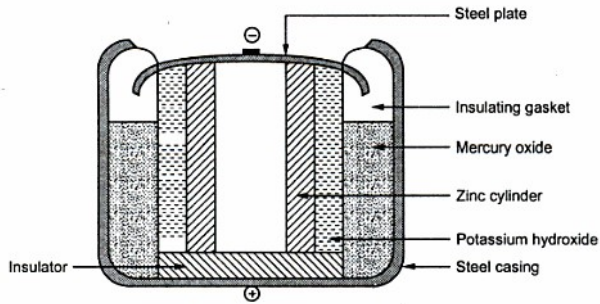

Fig. 1.21 Mercury Cell

The zinc electrode acting as negative terminal is made in the form of a hollow cylinder. The steel casing acts as a positive terminal. The layer of mercury oxide covers the electrolyte which is solution of KOH and ZnO. The cell is sealed with the help of insulating gasket.

1.17.2.1 Chemical reaction

The net chemical reaction involved in the cell is,



1.17.2.2 Features of the cell

1. The chemical reaction does not evolve any gas hence no polarisation.
2. The cell maintains its e.m.f. for longer time in working condition.
3. The terminal voltage is about 1.2 to 1.3 V.
4. It has long life.
5. It has high ratio of output energy to weight of about 90 – 100 Wh/kg.
6. Costlier than dry cell.
7. It has high energy to volume ratio of about 500 – 600 Wh/L.
8. It has high efficiency.
9. Good resistance to shocks and vibrations.
10. Disposal is difficult due to presence of poisonous materials inside.

1.17.2.3 Applications

The cells are preferred for providing power to small devices as available in miniature button shapes. The various applications are,

1. Hearing aids.
2. Electronic calculators.
3. Electronic clocks.
4. Guided missiles.
5. Medical electronic appliances such as pace makers.
6. Audio devices and cameras.

1.18 Secondary Cells

It is seen that the secondary cells are rechargeable cells as the chemical reactions in it are reversible. The two types of secondary cells are,

1. Lead acid cell
2. Alkaline cell

Let us discuss these cells in detail.

1.19 Lead Acid Battery

The various parts of lead acid battery are,

1. **Positive plate or Anode** : It is lead peroxide (PbO_2) plate of chocolate, dark brown colour.
2. **Negative plate or Cathode** : It is made up of pure lead (Pb) which is grey in colour.

3. **Electrolyte** : For the necessary chemical action aqueous solution of sulphuric acid (H_2SO_4) is used as an electrolyte.
4. **Separators** : The positive and negative plates are arranged in groups and are placed alternately. The separators are used to prevent them from coming in contact with each other short circuiting the cell.
5. **Container** : The entire assembly of plates along with the solution is placed in the plastic or ceramic container.
6. **Bottom blocks** : To prevent the short circuiting of cell due to the active material fallen from the plates, the space known as bottom blocks is provided at the bottom of the container.
7. **Plate connector** : The number of negative and positive plates are assembled alternately. To connect the positive plates together separate connectors are used which are called plate connectors. The upward connections of the plate connectors are nothing but the terminals of the cell.
8. **Vent-plug** : These are made up of rubber and screwed to the cover of the cell. Its function is to allow the escape of gases and prevent escape of electrolyte.

The Fig. 1.22 shows the construction of lead acid battery.

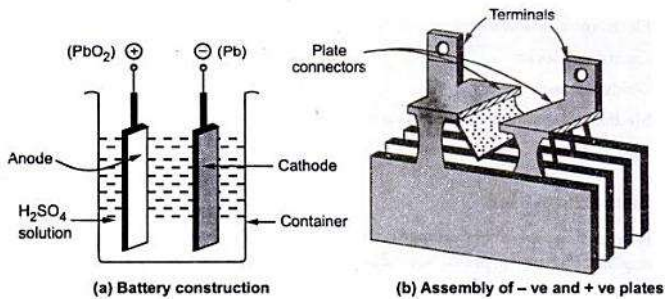

Fig. 1.22 Construction of lead acid battery

The various plates are welded to the plate connectors. The plates are immersed in H_2SO_4 solution. Each plate is a grid or frame work. Except some special assemblies, wide space between the plates is provided. In an alternate assembly of plates, the **negative plate is one more in number than positive**. So all the positive plates can work on both the sides.

1.19.1 Functions of Separators

The separators used have the following functions in the construction of lead acid battery :

1. Acting as mechanical spacer preventing the plates to come in contact with each other.
2. Prevent the growth of lead trees which may be formed on the negative plates and due to heavy accumulation may reach to positive plate to short circuit the cell.
3. Help in preventing the plates from shedding of the active material. The separators must be mechanically strong and must be porous to allow diffusion of the electrolyte through them.

1.19.2 Chemical Action in Lead Acid Battery

The chemical action in the lead acid battery can be divided into three processes :

1. First charging
2. Discharging
3. Recharging

Let us discuss these processes in detail.

1. First charging : When the current is passed for the first time through electrolyte, the H_2O in the electrolyte is electrolysed as,

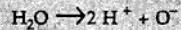

The hydrogen ions as positively charged get attracted towards one of the electrodes which acts as cathode (negative). The hydrogen does not combine with lead and hence cathode retains its original state and colour.

The oxygen ion as negatively charged gets attracted towards the other lead plate which acts as anode (positive). But this oxygen chemically combines with the lead (Pb) to form lead peroxide (PbO_2). Due to the formation of lead peroxide the anode becomes dark brown in colour.

Thus anode is dark brown due to the layer of lead peroxide deposited on it while the cathode is spongy lead electrode.

So there exists a potential difference between the positive anode and the negative cathode which can be used to drive the external circuit. The electrical energy obtained from chemical reaction is drawn out of the battery to the external circuit, which is called discharging.

2. Discharging : When the external supply is disconnected and a resistance is connected across the anode and cathode then current flows through the resistance, drawing an electrical energy from the battery. This is discharging. The direction of current is opposite to the direction of current at the time of first charging. The discharging is shown in the Fig. 1.23.

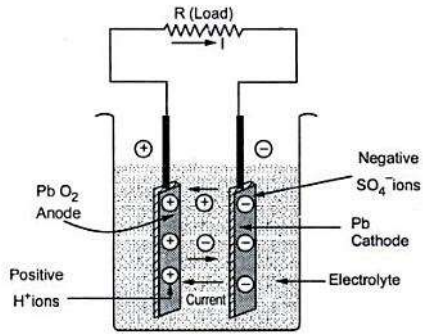
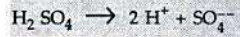

Fig. 1.23 Discharging

During the discharging, the directions of the ions are reversed. The H^+ ions now move towards anode and the SO_4^{--} ions move towards cathode.

This is because H_2SO_4 decomposes as,



At the anode, the hydrogen ions become free atoms and react with lead peroxide along with the H_2SO_4 and ultimately lead sulphate $PbSO_4$ results as,

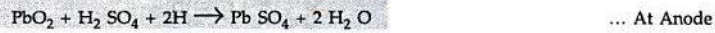

At the cathode, each SO_4^{--} ion become free SO_4 which reacts with the metallic lead to get lead sulphate.



Thus discharging results into formation of whitish lead sulphate on both the electrodes.

3. Recharging : The cell provides the discharge current for limited time and it is necessary to recharge it after regular time interval. Again an e.m.f. is injected through the cell terminals with the help of an external supply.

The charging is shown in the Fig. 1.24.

Due to this recharging current flows and following reactions take place,

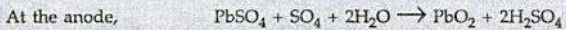

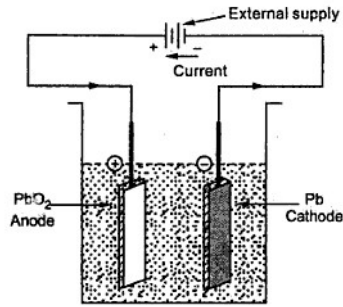

Fig. 1.24 Recharging the lead acid battery

Thus the PbO_2 gets formed at anode while lead sulphate layer on the cathode is reduced and gets converted to grey metallic lead. So the strength of the cell is regained. It can be seen from the reaction that water is used and H_2SO_4 is created. Hence the specific gravity of H_2SO_4 which is the charging indicator of battery, increases.

Key Point: *More the specific gravity of H_2SO_4 , better is the charging.*

The specific gravity is 1.25 to 1.28 for fully charged battery while it is about 1.17 to 1.15 for fully discharged battery. The voltage also can be used as a charging indicator. For fully charged battery it is 2.2 to 2.5 volts.

The chemical reaction during charging and discharging can be represented using single equation as,

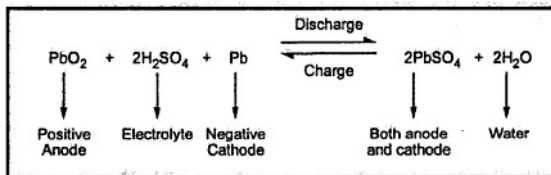

Fig. 1.25

1.19.3 Features of Lead Acid Battery

The various features of lead acid battery are,

1. The capacity is about 100 to 300 ampere-hours.
2. The voltage is 2.2 V for fully charged condition.
3. The cost is low.

4. The internal resistance is very low.
5. The current ratings are high.
6. The ampere-hour efficiency is about 90 to 95% with 10 hour rate.

1.19.4 Conditions of a Fully Charged Battery

For identifying whether the battery is fully charged or not, following conditions must be observed,

1. The specific gravity of H_2SO_4 must be 1.25 to 1.28.
2. The voltage stops to rise and its value is about 2.2 to 2.5 V.
3. Violent gasing starts as battery is fully charged.
4. The colour of positive plate becomes dark brown while the colour of negative plate becomes slate grey.

1.19.5 Maintenances and Precautions to be taken for Lead Acid Battery

The following steps must be taken in the maintenance of the lead acid battery,

1. The battery must be recharged immediately when it discharges.
2. The level of the electrolyte must be kept above the top of plates so the plates remain completely immersed.
3. The rate of charge and discharge should not be exceeded as specified by the manufacturers.
4. Maintain the specific gravity of the electrolyte between 1.28 to 1.18.
5. The loss of water due to evaporation and gasing must be made up using only distilled water.
6. The connecting plugs should be kept clean and properly tightened.
7. It should not be discharged till its voltage falls below 1.8 V.
8. When not in use, it should be fully charged and stored in a cool and dry place.
9. It should not be kept long in discharged condition. Otherwise $PbSO_4$ gets converted to hard substance which is difficult to remove by charging. This is called **sulphating**. Thus sulphating should be avoided.
10. The battery must be given periodic overcharge at half the normal rate to remove white sulphate.
11. The temperature of the battery should not exceed $45^\circ C$ otherwise plates deteriorate rapidly.
12. The battery terminals should not be shorted to check whether battery is charged or not.
13. Always keep the surface of the container dry.

14. No sulphuric acid should be added till it is sure that low specific gravity is due to under charge and not due to white sulphate formed on plates.
15. The acid used must be pure without any impurity and colourless.
16. The sparks and flames must be kept away from the battery.

1.19.6 Testing Procedure for Lead Acid Battery

1. **Using hydrometer :** The testing basically involves the checking of specific gravity of the sulphuric acid. It can be checked by the use of hydrometer. The hydrometer consists of a glass float with a calibrated stem placed in a syringe. The readings on hydrometer are shown in the Fig. 1.26.

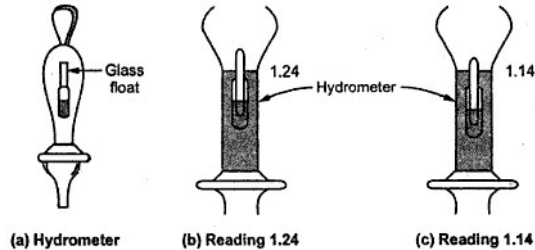

Fig. 1.26 Testing lead acid battery

2. **Using cell tester :** Another method of testing the lead acid battery is called **high discharge test** or **short circuit test**. The cell tester is used for this test. It consists of 0 - 3 V voltmeter shunted by a low resistance. The low resistance shunt is connected between two prongs as shown in the Fig. 1.27. The prongs are pressed against the cell terminals. A high discharge current flows through the low resistance and cell voltage is indicated by the voltmeter.

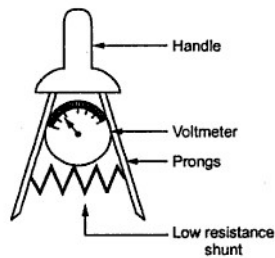

Fig. 1.27 Cell tester

The battery with full charge, without sulphatation occurred in it, shows proper reading on voltmeter. But battery which is sulphated, showing other indications of full charge will show low voltage reading. Thus this is reliable method of testing the lead acid battery.

Thus if the reading on voltmeter is less than 1.8 V, the battery needs charging while if it is more than 2.5 V it is overcharged. According to specific gravity reading the distilled water should be added to bring specific gravity back to its normal value.

1.19.7 Applications

The various applications of lead acid battery are,

1. In emergency lighting systems.
2. In automobiles for starting.
3. Uninterrupted power supply systems.
4. Railway signalling.
5. Electrical substations and the power stations.
6. For compensating feeder drops in case of heavy loads.
7. For energizing the trip coils of the relays and the switch gears.
8. As a source of supply in mines and telephone exchanges.

Apart from these applications, the lead acid batteries are used in various other areas also like telephone systems, aeroplanes, marine applications etc.

1.20 Battery Capacity

The battery capacity is specified in ampere-hours (Ah).

Key Point: It indicates the amount of electricity which a battery can supply at the specified discharge rate, till its voltage falls to a specified value.

For a lead acid battery, the discharge rate is specified as 10 hours or 8 hours while the value of voltage to which it should fall is specified as 1.8 V.

Mathematically the product of discharge current in amperes and the time for discharge in hours till voltage falls to a specified value is the capacity of a battery.

$$\text{Battery capacity} = I_D \times T_D \text{ (Ah)}$$

Where

I_D = Discharge current in amperes

T_D = Time of discharge in hours till voltage falls to a specified value.

Sometimes it is specified as watt-hours (Wh). It is the product of the average voltage during discharge and the ampere hour capacity of a battery.

The battery capacity depends on the following factors,

1. **Discharge rate** : As the rate of discharge increases, the battery capacity decreases.
2. **Specific gravity of electrolyte** : More the specific gravity of electrolyte, more is the battery capacity as it decides internal resistance of the battery.
3. **Temperature** : As temperature increases, the battery capacity increases. This is shown in the Fig. 1.28.

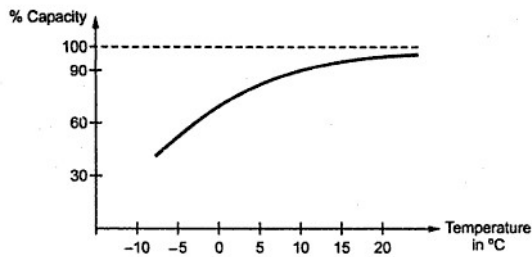

Fig. 1.28 Effect of temperature on battery capacity

4. Size of the plates : This is related to the amount of active material present in the battery.

1.21 Battery Efficiency

Mainly the battery efficiency is defined as the ratio of output during discharging to the input required during charging, to regain the original state of the battery.

It is defined in many ways as,

1. Ampere-hour efficiency or quantity efficiency
2. Watt-hour efficiency or energy efficiency

1.21.1 Ampere-hour Efficiency

It is defined as ratio of output in ampere-hours during discharging to the input in ampere-hours during charging. It is denoted as η_{Ah} .

$$\therefore \eta_{Ah} = \frac{\text{Ampere-hours on discharge}}{\text{Ampere-hours on charge}}$$

$$\therefore \% \eta_{Ah} = \left[\frac{\text{Current} \times \text{Time on discharge}}{\text{Current} \times \text{Time on charge}} \right] \times 100$$

For lead acid battery, it ranges between 80 % to 90 %.

1.21.2 Watt-hour Efficiency

It is defined as the ratio of output in watt-hours during discharging to the input in watt-hours during charging. It is denoted as η_{Wh} .

$$\therefore \eta_{Wh} = \frac{\text{Watt-hours on discharge}}{\text{Watt-hours on charge}}$$

$$\therefore \% \eta_{Wh} = \left\{ \frac{[\text{Voltage during discharge (average)}] \times [\text{Current} \times \text{time at discharge}]}{[\text{Voltage during charge (average)}] \times [\text{Current} \times \text{time at charge}]} \right\} \times 100$$

$$= \eta_{Ah} \times \frac{\text{Average voltage during discharge}}{\text{Average voltage during charge}}$$

Key Point: It can be seen that as average voltage during discharge is less than the average voltage during charge, the watt-hour efficiency is always less than the ampere-hour efficiency.

For lead acid battery, watt-hour efficiency ranges between 70 % to 80 %.

1.22 Charge and Discharge Curves

The behaviour of battery voltage with respect to the time in hours of charging or discharging at normal rate is indicated by the curves called charge and discharge curves.

During discharge of the lead acid cell, the voltage decreases from about 2.1 V to 1.8 V, when cell is said to be completely discharged. The discharge rate is always specified as 8 hours, 10 hours etc.

During charging of the lead acid cell, the voltage increases from 1.8 V to about 2.5 V to 2.7 V, when cell is said to be completely charged. If the discharge rate is high, the curve is more drooping as voltage decreases faster. Such typical charge and discharge curves for lead-acid cell are shown in the Fig. 1.29. While discharging the voltage decreases to 2 V very fast, then remains constant for long period and at the end of discharge period falls to 1.8 V. While charging, initially it rises quickly to 2.1 to 2.2 V and then remains constant for long time. At the end of charging period it increases to 2.5 to 2.7 V.

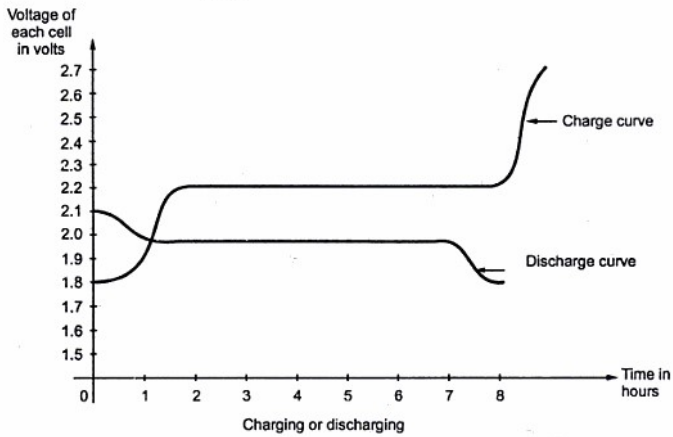

Fig. 1.29

1.23 Battery Charging

During charging, the chemical action takes place which is exactly opposite to that of discharging. Thus current in opposite direction to that at the time of discharge, is passed through the battery. For this the voltage applied is in excess of the voltage of the battery or cell. The battery voltage acts in opposite direction to that of the applied voltage and hence called back e.m.f. The charging current can be obtained as,

$$\text{Charging current} = \frac{E_a - E_b}{R + r}$$

- Where
- E_a = Applied voltage
 - E_b = Back e.m.f. i.e. battery voltage
 - R = External resistance in the circuit
 - r = Internal resistance of the battery

Simple battery charging circuit used to charge the battery from d.c. supply is shown in the Fig. 1.30.

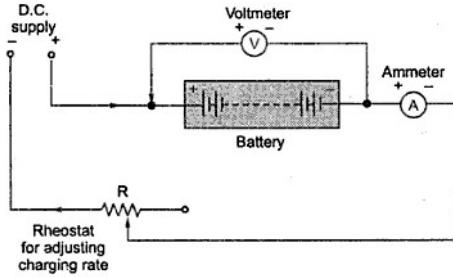

Fig. 1.30 Battery charging

The ammeter measures the charging current which is called charging rate, which can be adjusted using the external resistance R . The voltmeter measures the battery voltage. It is necessary that the positive terminal of the battery must be connected to the positive of the D.C. supply.

The charging current must be adjusted such that the temperature of the electrolyte will not increase beyond 100° to 110° F .

1.23.1 Indications of Fully Charged Battery

The various indications of the fully charged cells are,

1. **Specific gravity** : The specific gravity of the fully charged cell increases upto 1.28 from about 1.18.
2. **Gassing** : When the cell is fully charged, it starts liberating the gas freely. In lead acid battery the hydrogen is liberated at cathode while oxygen at the anode. Gassing is a good indication of fully charged battery. Some acid particles may go out with the gases hence the charging room must be kept well ventilated.
3. **Voltage** : The voltage of the fully charged cell is about 2.7 V.
4. **Colour** : The colour of the plates changes for fully charged cell. Colour of the positive plate changes to dark chocolate brown while that of negative plate changes to grey colour. But as plates are immersed in the electrolyte, this indication is not clearly visible.

1.24 Charging Methods

The main methods of battery charging are,

1. Constant current method
2. Constant voltage method
3. Rectifier method

1.24.1 Constant Current Method

When the supply is high voltage but battery to be charged is of low voltage, then this method is used. The number of batteries which can be charged are connected in series across the available d.c. voltage. The constant current is maintained through the batteries with the help of variable resistor connected in series. The circuit is shown in the Fig. 1.31.

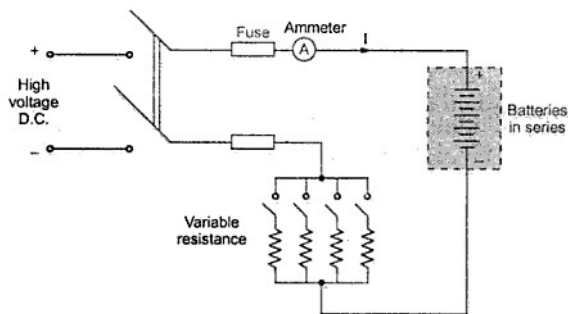

Fig. 1.31 Constant current method

The charging time required in this method is comparatively large. Hence in modern charger the number of charging circuits are used to give a variation of charging rates. Initially higher charging rate is used and later on lower charging rate is preferred.

1.24.2 Constant Voltage Method

In this method, the constant voltage is applied across the cells, connecting them in parallel. The charging current varies according to the state of the charge of each battery. The batteries to be charged are connected in 6 or 12 volt units across the positive and negative busbars i.e. mains supply. When the battery is first connected, a high charging current flows but as the terminal voltage of the battery increases, the charging current reduces automatically. At the end of the full charge, the voltage of the battery is equal to the voltage of the busbars and no current flows. The charging time required is much less in this method.

Another practically used method is called trickle charge. In this method, the charging current is maintained slightly more than the load current, through the battery. The load is constantly connected to the battery. So battery remains always in fully charged condition.

The Fig. 1.32 shows the cascade resistances used for the charging of batteries on d.c. mains supply.

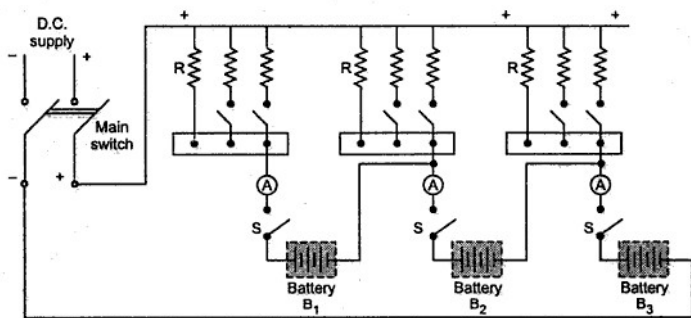

Fig. 1.32

The Fig. 1.33 shows the parallel charging circuit in which 2 separate groups each of 4 cells in series are connected in parallel across the mains.

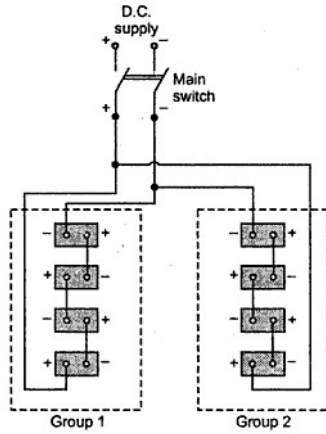

Fig. 1.33 Parallel charging circuit

1.24.3 Rectifier Method

When battery is required to be charged from a.c. supply, the rectifier method is used. The rectifier converts a.c. supply to d.c. Generally bridge rectifier is used for this purpose. The Fig. 1.34 shows the circuit used for rectifier method.

The step down transformer lowers the a.c. supply voltage as per the requirement. The bridge rectifier converts this low a.c. voltage to d.c. this is used to charge the battery.

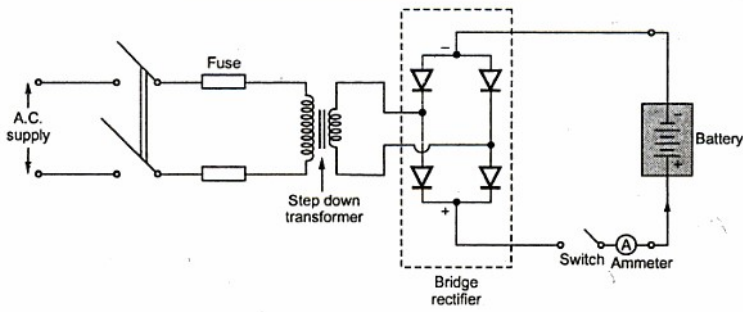

Fig. 1.34 Rectifier method

1.25 Grouping of Cells

The single cell is not sufficient to provide necessary voltage in many cases. Practically number of cells are grouped to obtain the battery which provides necessary voltage or current. The cells are grouped in three ways,

1. Series grouping
2. Parallel grouping
3. Series-parallel grouping

1.25.1 Series Grouping

The Fig. 1.35 shows the series grouping of cells so as to obtain the battery. There are n cells connected in series.

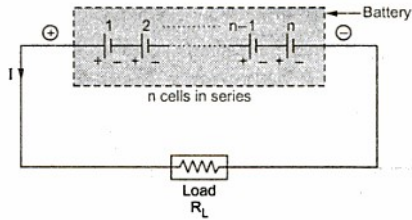

Fig. 1.35 Series grouping of cells

- Let
- E = E.M.F. of each cell
 - r = Internal resistance of each cell
- ∴ V = Total voltage available = n × E volts

$$R_T = \text{Total circuit resistance} = \text{load} + \text{cells}$$

$$= R_L + n \times r$$

$$I = \frac{\text{Total voltage}}{\text{Total resistance}} = \frac{V}{R_T} = \frac{nE}{R_L + nr} \text{ A}$$

Key Point: In series circuit, current remains same. So this method does not improve current capacity. The current capacity is same as that of each cell connected in series. But voltage can be increased by increasing number of cells n .

1.25.2 Parallel Grouping

In this method, positive terminals of cells are connected together and negative terminals are connected together as shown in the Fig. 1.36.

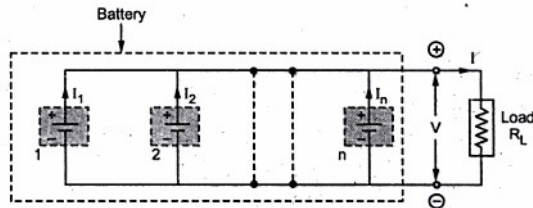

Fig. 1.36 Parallel grouping of cells

The terminal e.m.f. of each battery must be same as E .

$$\therefore V = \text{Battery voltage} = E = \text{e.m.f. of each cell}$$

$$r = \text{Internal resistance of each cell}$$

$$I_n = \text{Current through } n\text{th branch}$$

$$\therefore I = \text{Total current}$$

$$I = I_1 + I_2 + I_3 + \dots + I_n$$

Key Point: It can be seen that in parallel grouping, the voltage remains same but by increasing number of cells the current capacity can be increased.

In series grouping current rating of each cell must be same while in parallel grouping voltage rating of each cell must be same.

1.25.3 Series-Parallel Grouping

Practically the various groups can be connected in parallel where each group is a series combination of cells as shown in the Fig. 1.37.

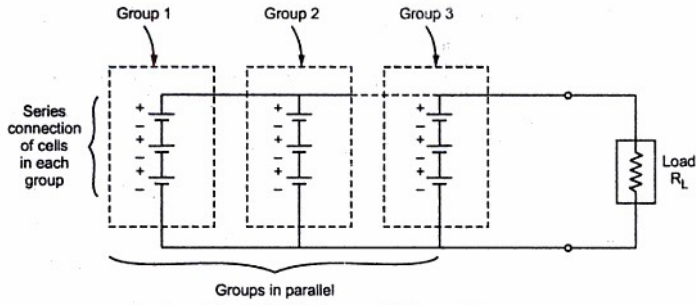

Fig. 1.37 Series-parallel grouping

This is used to satisfy both voltage and current requirement of the load.

1.26 Alkaline Cells

The secondary cells can be alkaline cells. These are of two types.

1. Nickel - iron cell or Edison cell
2. Nickel - cadmium or Nife Cell or Junger cell

1.27 Nickel - Iron Cell

In this cell,

Positive Plate → Nickel hydroxide $[(Ni(OH)_3)]$
 Negative Plate → Spongy iron (Fe)

The electrolyte is an alkali of 21 % solution of potassium hydroxide solution (KOH).

The insulated rods are used to separate the positive and negative plates.

The Fig. 1.38 shows the construction of Nickel-iron cell.

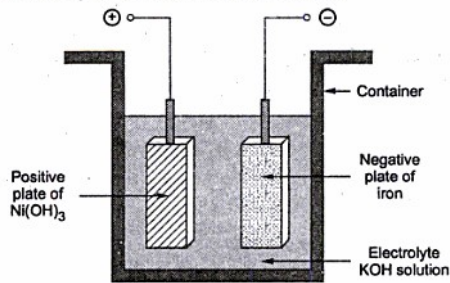

Fig. 1.38 Construction of Nickel-iron cell

Urheberrechtlich geschütztes Material

1.27.1 Chemical Reaction

In a charged condition, the material of positive plate is Ni(OH)_3 and that of negative plate is iron. When it is connected to load and starts discharging, the nickel hydroxide gets converted to lower nickel hydroxide as Ni(OH)_2 while the iron on negative plate gets converted to ferrous hydroxide Fe(OH)_2 . When charged again, reversible reaction takes place, regaining the material on each plate.

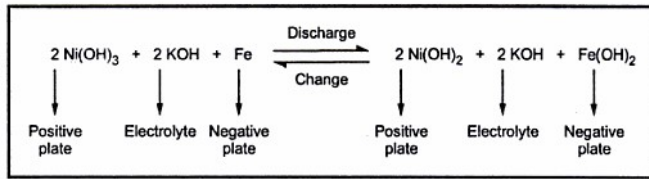

Fig. 1.39 Total reaction

Key Point: An electrolyte does not undergo any chemical change. Hence its specific gravity remains constant at about 1.2.

By connecting various Nickel-iron cells properly, the Nickel-iron battery is obtained.

1.27.2 Electrical Characteristics

The electric characteristics indicates the variations in the terminal voltage of cell against the charging or discharging hours. The Fig. 1.40 shows the electrical characteristics of Nickel-iron cell during charging and discharging.

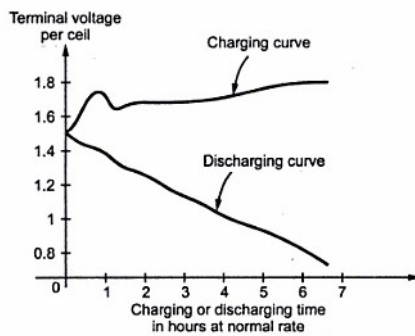

Fig. 1.40 Electrical characteristics of Nickel-iron cell

When fully charged its voltage is about 1.4 V and during discharging it reduces to about 1.1 to 1 V. During charging, the average charging voltage is 1.7 to 1.75 V.

Key Point: For Nickel-iron cell there is no specific minimum voltage below which the cell must not be discharged to avoid damage to the cell.

1.27.3 Capacity

It is mentioned that electrolyte does not undergo any chemical change for this cell. Thus specific gravity of the electrolyte remains constant for long periods. Hence rate of discharge does not affect ampere-hour capacity of this cell significantly. Thus Ah capacity of Nickel-iron cell remains almost constant. But it does get affected by the temperature. The Fig. 1.41 shows the Ah capacity against discharging time curve for Nickel-iron cell.

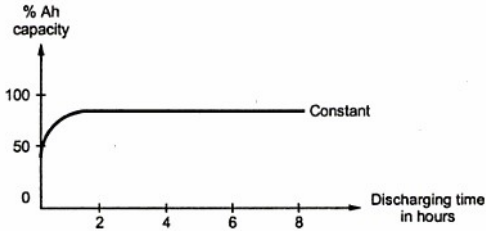

Fig. 1.41 Ah capacity against discharge time curve

1.27.4 Efficiency

The internal resistance of Nickel-iron cell is higher than lead acid cell hence both the efficiencies ampere-hour as well as watt-hour are less than that of lead acid cell. The ampere-hour efficiency is about 80 % while the watt-hour efficiency is about 60 %.

1.27.5 Advantages

The various advantages of Nickel-iron cell are,

1. Light in weight compared to lead acid cell.
2. Compact construction.
3. Mechanically strong and can sustain considerable vibrations.
4. Free from sulphatation and corrosion.
5. Less maintenance is required
6. Do not evolve dangerous attacking fumes.
7. Gives longer service life.

1.27.6 Disadvantages

The various disadvantages of Nickel-iron cell are,

1. High initial cost.
2. Low voltage per cell of about 1.2 V.
3. High internal resistance.
4. Lower operating efficiency.

1.27.7 Application

The Nickel-iron batteries are used in,

1. Mine locomotives and mine safety lamps
2. Space ship
3. Repeater wireless station
4. To supply power to tractors, submarines, aeroplanes etc.
5. In the railways for lighting and airconditioning purposes.

1.28 Nickel - Cadmium Cell

The construction of this cell is similar to the nickel-iron cell except the active material used for the negative plate.

Positive plate → Nickel hydroxide $[\text{Ni}(\text{OH})_2]$

Negative plate → Cadmium (Cd)

The electrolyte used is again 21 % solution of potassium hydroxide (KOH) in distilled water. The specific gravity of the electrolyte is about 1.2.

Little iron is added to cadmium to get negative plate. The iron prevents the caking of active material and losing its porosity.

The Fig. 1.42 shows the construction of Nickel-cadmium cell.

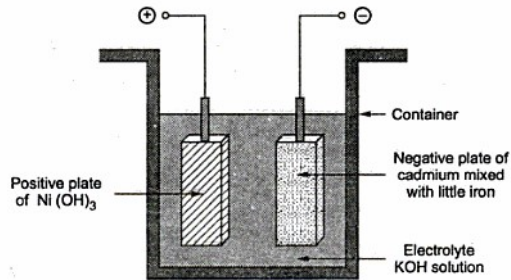

Fig. 1.42 Construction of Nickel-Cadmium cell

1.28.1 Chemical Reaction

In this cell also, in working condition Ni(OH)_3 gets converted to lower nickel hydroxide as Ni(OH)_2 while cadmium hydroxide Cd(OH)_2 gets formed at the negative plate. During charging reverse reaction takes place. The electrolyte does not undergo any chemical change.

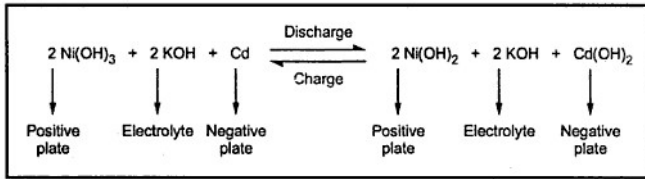

Fig. 1.43 Total reaction

1.28.2 Features

1. The electrical characteristics are similar to the Nickel-iron cell.
2. Due to use of cadmium, internal resistance is low.
3. The efficiencies are little bit higher than Nickel-iron cell.
4. Advantages and disadvantages are same as that of Nickel-iron cell.
5. The various charging methods such as constant current, constant voltage, trickle charging can be used.

1.28.3 Applications

The various applications of Nickel-cadmium battery are,

1. In railways for lighting and air conditioning systems.
2. In military aeroplanes, helicopters and commercial airlines for starting engines and provide emergency power supply.
3. In photographic equipments such as movie cameras and photoflash.
4. In electric shavers.
5. Due to small size in variety of cordless electronic devices.

1.29 Comparison of Various Batteries

Sr. No.	Particular	Lead acid cell	Nickel-Iron cell	Nickel-Cadmium Cell
1.	Positive plate	Lead peroxide (PbO ₂)	Nickel hydroxide Ni(OH) ₃	Nickel hydroxide Ni (OH) ₃
2.	Negative plate	Lead (Pb)	Iron (Fe)	Cadmium (Cd)
3.	Electrolyte	Sulphuric acid H ₂ SO ₄	Potassium hydroxide KOH	Potassium hydroxide KOH
4.	Average e.m.f.	2.0 V/cell	1.2 V/cell	1.2 V/cell
5.	Internal resistance	Low	High	Low
6.	Ah efficiency	90 to 95 %	70-80 %	70-80 %
7.	Wh efficiency	72 to 80%	55-60%	55-60%
8.	Ah capacity	Depends on discharge rate and temperature	Depends only on temperature	Depends only on temperature
9.	Cost	Less expensive	Almost twice the lead acid cell	Almost twice the lead acid cell
10.	Life	1250 charges and discharges	About 8 to 10 years	Very long life
11.	Weight	Moderate	Light	More heavy
12.	Mechanical strength	Poor	Good	Good

1.30 Comparison of Primary and Secondary Cells

Sr. No.	Primary Cells	Secondary Cells
1.	Electrical energy is directly obtained from chemical energy.	Electrical energy is present in the cell in the form of chemical energy and then converted to electrical energy.
2.	The chemical actions are irreversible.	The chemical actions are reversible.
3.	Cell is completely replaced when it goes down.	The cell is recharged back when it goes down.
4.	Polarisation is present.	Polarisation is absent.
5.	Low efficiency.	Efficiency is high

6.	Capacity is low.	Higher capacity.
7.	Less cost.	High initial cost.
8.	No maintenance required.	Frequent charging and other maintenance is required.
9.	Examples are dry cell, mercury cell, zinc-chloride cell	Examples are Nickel-iron, lead acid and Nickel-cadmium

1.31 NiMH Battery

Now a days, number of battery powered portable electronic devices are developed. The consumer demands higher energy rechargeable batteries which are capable of delivering longer service between recharges. The sealed nickel - metal hydride (NiMH) rechargeable battery satisfies the consumer demand and provides far improved performance compared to conventional rechargeable batteries. The NiMH battery has higher energy capacity and hence capable of providing longer service life.

1.31.1 Construction

This type of battery uses Nickel oxyhydroxide (NiOOH) as the active material in the positive electrode. While the negative active material is the hydrogen in the charged state, in the form of metal hydride. This metal hydride is an alloy which can undergo a reversible hydrogen absorbing and deabsorbing reaction when the battery is charged and discharged.

Typically there are two types of classes of the alloy which is used as the electrode material in the NiMH battery.

1. AB_5 alloy of which $LaNi_5$ is the example.
2. AB_2 alloy of which $TiMn_2$ or $ZrMn_2$ are examples.

Practically AB_5 alloys are more preferred as they offer better corrosion resistance characteristics which provides longer cycle life and better rechargeability. These alloys have large hydrogen storing capability. The low hydrogen pressure alloy and highly pure materials can minimize the self discharge.

Both the electrodes use highly porous structure and large surface areas. This provides low internal resistance for the cell. The positive electrode is highly porous nickel-felt substrate into which the nickel compounds are pasted. While a perforated nickel-plated steel foil is used for the negative electrode onto which the plastic bonded active hydrogen storage alloy is coated.

The electrolyte used is an aqueous solution of potassium hydroxide (KOH). In NiMH battery, the minimum amount of electrolyte is used with most of the liquid being absorbed by the separator and the electrodes. This design helps the diffusion of oxygen to the negative electrode at the end of charge for the "oxygen recombination" reaction.

The NiMH battery is designed with a discharge and charge reserve in the negative electrode. This is shown in the Fig. 1.44

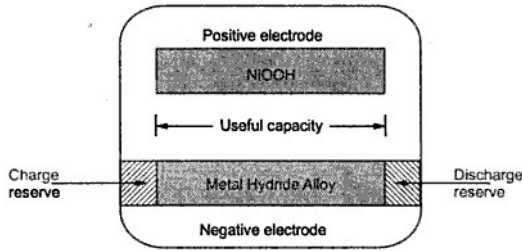

Fig. 1.44 Schematic representation of NiMH battery

In case of overdischarge, the gassing and the degradation of the cell is minimized by the discharge reserve.

In case of overcharge, the charge reserve make sure that the battery maintains low internal pressure.

The standard size NiMH batteries are constructed with cylindrical and prismatic type of nickel-metal hydride cells.

1.31.2 Cell Reactions

The cell reactions are divided into,

1. Cell reactions during charge.
2. Cell reactions during discharge.

1. **During Charge** : The positive electrode reaches to the full charge before negative electrode and causes the oxygen to evolve.

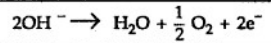

Due to minimum amount of electrolyte, the oxygen gas diffuses through the separator to the negative electrode. This design is called 'starved electrolyte' design of the cell.

The oxygen reacts with metal hydride at the negative electrode, to produce water.

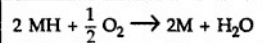

2. **During Discharge** : The nickel oxyhydroxide is converted to nickel hydroxide.

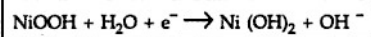

While the metal hydride is oxidized to the metal alloy (M).

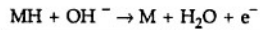

Thus the overall reaction on discharge is,

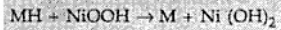

1.31.3 Features

The various features of NiMH batteries are,

1. Higher capacity which is about 40 % longer life than ordinary NiCd battery of same size.
2. The charging is very fast in about one hour.
3. The cycle life is very long upto 500 charge / discharge cycles.
4. The internal resistance is very low due to 'starved electrolyte' type of design.
5. No pollution or effect on an environment as it does not contain any cadmium.
6. It is capable of performing well at extremes temperatures, on discharge from -20°C to $+50^\circ\text{C}$ and on charge from 0°C to 45°C .
7. Due to higher energy density, battery volume and weight is minimum.
8. It has wide voltage range.
9. It is manufactured with special high impact and flame retardant polymers hence durable.
10. The various charging methods like quick charge, fast charge, trickle charge can be used for charging.

1.31.4 General Characteristics

The discharge characteristics of NiMH battery is similar to that of NiCd battery. On charging, the open circuit voltage ranges from 1.25 to 1.35 volts/cell. On discharge, the nominal voltage is 1.2 volts/cell and the typical end voltage is 1 volt/cell.

The Fig. 1.45 shows the discharge characteristics of NiCd and NiMH batteries of same size. (See Fig. 1.45 on next page)

Both the batteries show the flat characteristics almost throughout the discharge. The midpoint voltage is between 1.25 to 1.1 V, which depends on the discharge load.

1.31.5 Self Discharge Characteristics

During storage, the NiMH battery discharges on its own. This is due to the reaction of residual hydrogen in the battery with the positive electrode. This causes slow and reversible decomposition of positive electrode. This is called self discharge of the cell. The rate of such a self discharge depends on the time for which the cell is stored and the temperature at which the cell is stored. At higher temperature, the rate of self discharge is

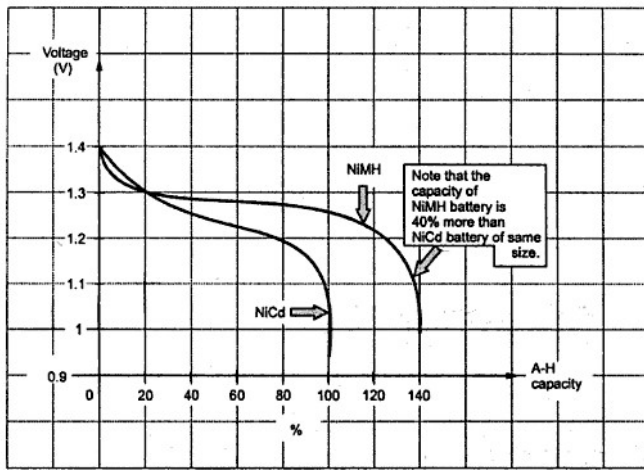

Fig. 1.45 Discharge characteristics

also high. The Fig. 1.46 shows the self discharge characteristics of NiMH cells at various temperatures.

The long term storage of NiMH battery in charged or discharged state has no permanent effect on the battery capacity.

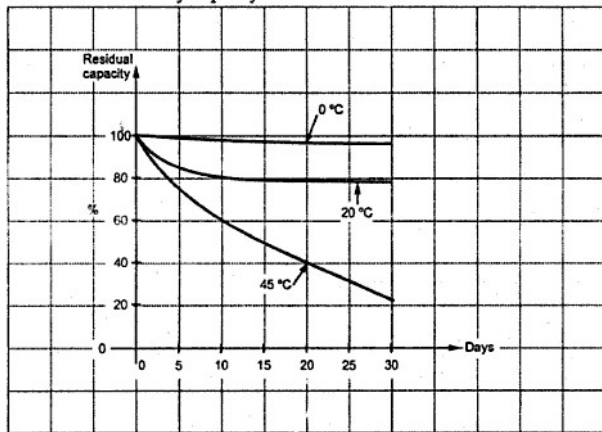

Fig. 1.46 Self discharge curves for NiMH cells

Key Point: The loss in capacity due to self discharge is reversible and can be recovered to full capacity by repeated charge / discharge cycles.

Even the capacity loss due to storage upto one year can be recovered. But long term storage at high temperatures can damage seals and separators. The proper temperature range for the storage of NiMH batteries is 10 °C to 30 °C.

1.31.6 Recharging Characteristics

The recharging characteristics of NiMH and NiCd batteries are almost same. For NiMH battery a proper charge control is necessary as it is more sensitive to overcharging.

The most common method used for charging the NiMH battery is constant current charge method with current controlled to avoid excessive temperature rise.

The Fig. 1.47 shows the typical charge-voltage characteristics of NiCd and NiMH batteries. The curves are almost flat when charged at constant current rate. Initially there is sharp increase in the voltage and similarly at about 80 % of charge, there is sharp rise in the voltages. But in the overcharging the NiCd batteries show the prominent voltage drop compared to NiMH batteries.

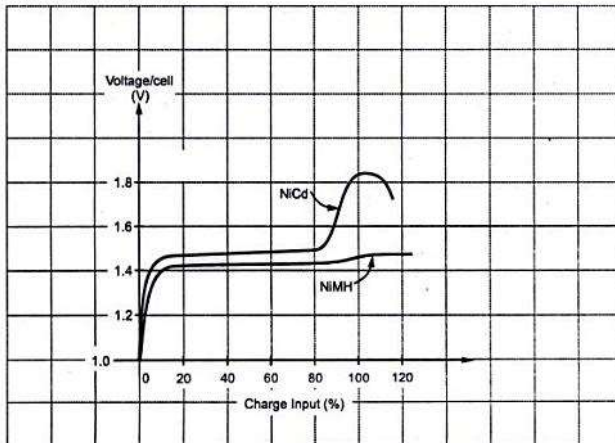

Fig. 1.47 Typical charge-voltage characteristics

1.31.7 Safety Precautions

The following care must be taken about the NiMH batteries for the safety purposes,

1. The battery should not be disassembled or opened. This can cause very high short circuit currents and may result into fire.

2. Keep and use the batteries away from the heat sources. Do not subject the battery to heat or do not dispose the battery in a fire. Store the battery at the recommended temperature.
3. Do not overcharge the battery. Due to this the battery may vent and hydrogen gas may be released. This gas can form explosive mixtures with the air.
4. Do not expose battery to a source of ignition or do not use in the air tight device compartments.
5. Do not use the battery for long time exceeding its specified ranges though the short term use may be possible.
6. Do not drop or do not subject to the strong mechanical shocks.

1.31.8 Applications

The various applications of NiMH battery are cellular phones, portable computers and many consumer electronic products. The batteries are used in digital cameras, cordless electronic devices, electronic toys and providing emergency supply to various electronic instruments. As the NiMH batteries are expensive, main application areas are cellular phones and laptop computers.

1.31.9 Comparison

No.	Parameter	Nickel-Cadmium (NiCd)	Nickel metal hydride (NiMH)
1.	Positive electrode	Nickel hydroxide Ni(OH)_3	Nickel oxyhydroxide NiOOH
2.	Negative electrode	Cadmium (Cd)	Metal hydride alloy (MH)
3.	Electrolyte	Potassium hydroxide (KOH)	Potassium hydroxide (KOH)
4.	Internal resistance	Low	Very low
5.	Life	Very long	Very very long
6.	Weight	Heavy	Light
7.	Mechanical strength	Good	Very good
8.	Gravimetric energy density	50 Wh / kg	55 Wh / kg
9.	Volumetric energy density	140 Wh / L	180 Wh / L
10.	Self discharge at 20 °C	15 - 20 % per month	20 - 30 % per month
11.	Cost	Best cost per performance value	Very high
12.	Protection	Internal short circuit protection is not provided.	Not supposed to produce internal shorts.

Note : The **gravimetric energy density** is a measure of how much energy a battery contains in comparison to its weight and typically expressed in watt-hour per kilogram (Wh/kg). The **volumetric energy density** is a measure of how much energy a battery contains in comparison to its volume and is typically expressed in watt-hour per litre (Wh/L).

Examples with Solutions

► **Example 1.17 :** A copper coil when connected to a 30 volts supply initially takes current of 3 A and has a mean temperature of 20 °C. After sometime the current flowing in the coil falls to 2.85 A, supply voltage remaining same. The mean temperature of the coil is then 33.4 °C. Determine the temperature coefficient of resistance at 0 °C, i.e. α_0 .

Also state if it is true that α can have

i) zero value ii) negative value and if yes for which materials. (Dec. - 2001)

Solution : $V = 30$ volts, $I_1 = 3$ Amp, $t_1 = 20$ °C, $I_2 = 2.85$ Amp, $t_2 = 33.4$ °C

Now we have, $R_1 = \frac{V}{I_1} = \frac{30}{3} = 10 \Omega$ at $t_1 = 20$ °C

$$R_2 = \frac{V}{I_2} = \frac{30}{2.85} = 10.52 \Omega \text{ at } t_2 = 33.4 \text{ °C}$$

We can write, $R_t = R_0 [1 + \alpha_0 t]$

$$\therefore R_1 = R_0 [1 + \alpha_0 t_1] \quad \dots (1)$$

$$R_2 = R_0 [1 + \alpha_0 t_2] \quad \dots (2)$$

Dividing equation (1) by (2), $\frac{R_1}{R_2} = \frac{1 + \alpha_0 t_1}{1 + \alpha_0 t_2}$

$$\frac{10}{10.52} = \frac{1 + \alpha_0 (20)}{1 + \alpha_0 (33.4)}$$

$$\therefore 0.9505 (1 + 33.4 \alpha_0) = 1 + 20 \alpha_0$$

$$\therefore 0.9505 - 1 = 20 \alpha_0 - (0.9505) (33.4) \alpha_0$$

Solving, $\alpha_0 = 4.2139 \times 10^{-3} / \text{°C}$

It is true that α can have zero value in case of alloys as with increase in temperature, alloys show almost no change in their resistance. The materials are Manganin and Eureka. It is also true that α can have negative value in case of insulating materials as with increase in temperature, resistance of insulating materials decreases. The materials are rubber, paper, mica, wood etc.

►► Example 1.18 : It is required to maintain a loading of 5 kW in a heating unit. At an initial temperature of 15 °C, a voltage of 200 V is necessary for this purpose. When the unit is settled down to a steady temperature, a voltage of 220 V is required to maintain the same loading. Estimate the final temperature of the heating element, if the resistance temperature co-efficient of the heating element is 0.0006 per °C at 0 °C. (May - 2002)

Solution : Power output = 5 kW = 5000 W, $\alpha_0 = 0.0006 / ^\circ\text{C}$

At $t_1 = 15 ^\circ\text{C}$, $V_1 = 200$ volt and $t_2, V_2 = 220$ volt

$$\text{At } 15 ^\circ\text{C}, \quad P = V_1 I_1 = V_1 \left(\frac{V_1}{R_1} \right) = \frac{V_1^2}{R_1}$$

$$\therefore R_1 = \frac{V_1^2}{P} = \frac{(200)^2}{5000} = 8 \Omega \quad \dots \text{ at } t_1 = 15 ^\circ\text{C}$$

$$\text{At } t_2 ^\circ\text{C}, \quad P = V_2 I_2 = V_2 \left(\frac{V_2}{R_2} \right) = \frac{V_2^2}{R_2} \quad \dots \text{ power remains same}$$

$$\therefore R_2 = \frac{V_2^2}{P} = \frac{(220)^2}{5000} = 9.68 \Omega \quad \dots \text{ at } t_2 ^\circ\text{C}$$

$$\text{Now we have,} \quad R_1 = R_0 [1 + \alpha_0 t_1] \quad \dots (1)$$

$$R_2 = R_0 [1 + \alpha_0 t_2] \quad \dots (2)$$

Dividing equation (2) by equation (1),

$$\frac{R_2}{R_1} = \frac{1 + \alpha_0 t_2}{1 + \alpha_0 t_1}$$

$$\therefore 1 + \alpha_0 t_2 = \frac{R_2}{R_1} (1 + \alpha_0 t_1) = \frac{9.68}{8} [1 + (0.0006)(15)]$$

$$\therefore \alpha_0 t_2 = 1.2208 - 1 = 0.2208$$

$$\therefore t_2 = 368.15 ^\circ\text{C}$$

►► Example 1.19 : If α_1 is the resistance temperature coefficient of a material at $t_1 ^\circ\text{C}$ and α_2 at $t_2 ^\circ\text{C}$. Then prove that,

$$(t_2 - t_1) = \frac{\alpha_1 - \alpha_2}{\alpha_1 \alpha_2} \quad (\text{Dec.-2005, Dec.-2007, May-2008})$$

Solution : The resistance temperature coefficient at any temperature $t ^\circ\text{C}$ can be obtained as,

$$\alpha_t = \frac{\alpha_0}{1 + \alpha_0 t}$$

$$\text{So } \alpha_1 = \frac{\alpha_0}{1 + \alpha_0 t_1} \text{ and } \alpha_2 = \frac{\alpha_0}{1 + \alpha_0 t_2}$$

where $\alpha_0 =$ resistance temperature coefficient at 0°C

$$\begin{aligned} \therefore \frac{1}{\alpha_2} - \frac{1}{\alpha_1} &= \frac{1 + \alpha_0 t_2}{\alpha_0} - \frac{1 + \alpha_0 t_1}{\alpha_0} = \frac{1 + \alpha_0 t_2 - 1 - \alpha_0 t_1}{\alpha_0} \\ &= \frac{\alpha_0(t_2 - t_1)}{\alpha_0} = t_2 - t_1 \end{aligned}$$

$$\therefore \boxed{\frac{\alpha_1 - \alpha_2}{\alpha_1 \alpha_2} = t_2 - t_1} \quad \dots \text{ Proved}$$

► **Example 1.20 :** It takes 30 minutes for an electric kettle to raise the temperature of 10 kg of water from 24°C to 100°C . The water equivalent of the container is 1 kg and the heat lost due to radiation is 400 kJ. Assuming the specific heat of water as $4200 \text{ J/kg}^\circ\text{K}$, calculate the current taken by the kettle from a supply of 200 V. (May - 1999)

Solution : Water equivalent of kettle = 1 kg

$$\therefore \text{Total mass } m = \text{mass of water} + \text{equivalent of container} = 10 + 1 = 11 \text{ kg}$$

$$\Delta t = t_2 - t_1 = 100 - 24 = 76^\circ\text{C}$$

Heat energy required to heat the water is,

$$H = m C \Delta t = 11 \times 4200 \times 76 = 3511.2 \text{ kJ}$$

$$\text{Net input required} = \text{Energy required} + \text{Energy lost}$$

$$= 3511.2 + 400 = 3911.2 \text{ kJ}$$

$$\text{Time} = 30 \text{ min} = 1800 \text{ sec}$$

$$\therefore \text{power input} = \frac{\text{input in J}}{\text{time in sec}} = \frac{3911.2 \times 10^3}{1800}$$

$$= 2172.88 \text{ W}$$

$$\therefore I = \frac{P_{\text{in}}}{V} = \frac{2172.88}{200} = 10.86 \text{ A}$$

► **Example 1.21 :** Find the amount of electrical energy expended in raising the temperature of 45 litres of water by 75°C . To what height could a load 5 tonnes be raised with the expenditure of the same amount of energy ? Assume efficiency of heating and lifting equipment to be 90 % and 70 % respectively. Assume the specific heat capacity of water to be $4186 \text{ J/kg}^\circ\text{K}$ and 1 litre of water to have a mass of 1 kg and 1 tonne is equal to 1000 kg. (May - 1998, May-2007)

Solution : $m = 45$ litres = 45 kg, $\Delta t = 75$ °C, $C = 4186$ J/kg °K

$$\begin{aligned} \therefore \text{Output energy} &= m C \Delta t = 45 \times 4186 \times 75 \\ &= 1.4127 \times 10^7 \text{ J} \end{aligned}$$

$$\begin{aligned} \therefore \text{Energy expended} &= \frac{\text{Output energy}}{\eta \text{ of heating equipment}} = \frac{1.4127 \times 10^7}{0.9} \\ &= 1.5697 \times 10^7 \text{ J} \end{aligned}$$

Now this much energy is to be utilised to lift a load of mass $m = 5$ tonnes = 5000 kg.

$$\therefore \text{Input energy} = 1.5697 \times 10^7 \text{ J}$$

$$\eta \text{ of lifting equipment} = 70 \% = 0.7$$

$$\begin{aligned} \therefore \text{Output energy} &= \eta \times \text{input} = 0.7 \times 1.5697 \times 10^7 \\ &= 1.098 \times 10^7 \text{ J} \end{aligned}$$

$$\text{Output energy} = mgh$$

$$\therefore 1.098 \times 10^7 = 5000 \times 9.81 \times h$$

$$\therefore h = 224.021 \text{ m}$$

So load can be raised to a height of 224.021 m.

► **Example 1.22 :** In case of power supply failure 7.5 kW electrical lighting and fan load of a commercial establishment is supplied by a small diesel generator set. Efficiency of diesel engine and the electrical generator are 55 % and 80 % respectively. Calculate the per kWh unit cost of this electricity if the set runs average 90 hours per month. The cost of diesel is Rs. 10/- per litre and the calorific value of diesel is 52,000 kJ/ltr. (Dec. - 1998)

Solution : Consider the system shown in the Fig. 1.48.

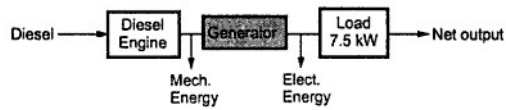

Fig. 1.48

$$\text{Output energy} = 7.5 \text{ kW}$$

$$\text{Monthly output} = 7.5 \times 90 = 675 \text{ kWh} = 675 \times 3600 \text{ kJ} = 2.43 \times 10^6 \text{ kJ}$$

$$\text{Engine } \eta_1 = 55 \% \text{ and Generator } \eta_2 = 80 \%$$

$$\text{Monthly input} = \frac{\text{output}}{\eta_1 \times \eta_2} = \frac{2.43 \times 10^6}{0.55 \times 0.8} = 5.522 \times 10^6 \text{ kJ}$$

Hence for an entire month the diesel required is,

$$\text{Diesel in litres} = \frac{5.522 \times 10^6}{52000} = 106.206 \text{ litres}$$

Hence the total cost = $106.206 \times 10 = \text{Rs. } 1062.06$

This is required to supply 675 kWh hence,

$$\text{Cost per kWh} = \frac{1062.06}{675} = \text{Rs. } 1.573$$

►► **Example 1.23 :** Determine the current flowing at the instant of switching a 60 watt lamp on a 230 V supply. The ambient temperature is 25 °C. The filament temperature is 2000 °C and the resistance temperature coefficient is 0.005 /°C at 0 °C. (Dec. - 1998)

Solution : $P = 60 \text{ W}$, $V = 230 \text{ V}$, $t_1 = 25 \text{ }^\circ\text{C}$, $t_2 = 2000 \text{ }^\circ\text{C}$

$R_2 =$ resistance of filament in ON condition

$$= \frac{V^2}{P} = \frac{(230)^2}{60} = 881.67 \Omega$$

$$\alpha_1 = \text{R.T.C at } t_1 = \frac{\alpha_0}{1 + \alpha_0 t_1} = \frac{0.005}{1 + 0.005 \times 25} = 4.44 \times 10^{-3} /^\circ\text{C}$$

Now $R_2 = R_1 (1 + \alpha_1 \Delta t)$

$$\therefore 881.67 = R_1 [1 + 4.44 \times 10^{-3} \times (2000 - 25)]$$

$$\therefore R_1 = 90.251 \Omega$$

$\therefore I =$ current at switching time

$$= \frac{V}{R_1} = \frac{230}{90.251} = 2.548 \text{ A}$$

►► **Example 1.24 :** At the instant of switching a 40 W lamp on a 230 V supply, the current is observed to be 2.5 A. The R.T.C. of filament is 0.0048 /°C at 0°C. The ambient temperature is 27 °C. Find the working temperature of the filament and current taken during normal operation. (May-2007)

Solution : $P = 40 \text{ W}$, $V = 230 \text{ V}$, $I = 2.5 \text{ A}$, $\alpha_0 = 0.0048 /^\circ\text{C}$

At the time of switching, temperature is ambient i.e. $t = 27 \text{ }^\circ\text{C}$,

$$\therefore R_{27} = \frac{V}{I} = \frac{230}{2.5} = 92 \Omega$$

Under working condition, power consumption of lamp is 40 W.

$$\therefore R_{12} = \frac{V^2}{P} = \frac{(230)^2}{40} = 1322.5 \Omega$$

$$\text{Now } R_{12} = R_{27} [1 + \alpha_{27} (t_2 - 27)]$$

$$\alpha_{27} = \frac{\alpha_0}{1 + \alpha_0 t} = \frac{0.0048}{1 + 0.0048 \times 27} = 4.2492 \times 10^{-3} / ^\circ\text{C}$$

$$\therefore 1322.5 = 92 [1 + 4.2492 \times 10^{-3} (t_2 - 27)]$$

$$\therefore 14.375 = 1 + 4.2492 \times 10^{-3} (t_2 - 27)$$

$$\therefore t_2 - 27 = 3147.6513$$

$$\therefore t_2 = 3174.6513 \text{ } ^\circ\text{C} \quad \dots \text{ working temperature}$$

$$\therefore I(\text{working}) = \frac{V}{R_{12}} = \frac{230}{1322.5} = 0.1739 \text{ A} \quad \dots \text{ working current}$$

► **Example 1.25 :** An electric motor is driving a train weighing, 100 thousand kilogram up on an inclined track of 1 in 100 at a speed of 60 km/h. The frictional force of tracks is 10 kg. per 1000 kg. of its weight. If the motor operates on 11 kV, find the current taken by the motor assuming the overall efficiency of the system as 70 %. (Dec. - 1999, Dec. - 2000)

Solution : The arrangement is shown in the Fig. 1.49.

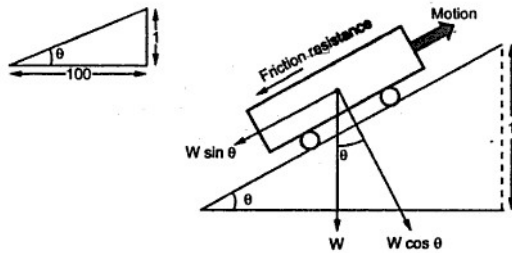

Fig. 1.49

Now, slope is 1 in 100.

$$\sin \theta = \tan \theta = \frac{1}{100} = 0.01 \quad \text{as } \theta \text{ is very small}$$

$$\therefore W \sin \theta = 100 \times 10^3 \times 0.01 = 1000 \text{ kg} = 1000 \times 9.81 = 9810 \text{ N}$$

$$\text{Track resistance} = 10 \text{ kg per } 1000 \text{ kg}$$

$$= \frac{10}{1000} \times 100 \times 10^3 = 1000 \text{ kg} = 9810 \text{ N}$$

Now, $W \sin \theta$ and track resistance, both are opposite to motion.

$$\therefore \text{Total resistance} = 9810 + 9810 = 19620 \text{ N}$$

$$\text{Work done} = \text{Force} \times \text{distance travelled in 1 sec} = 19620 \times d$$

$$\text{Now, Speed} = 60 \text{ km/h}$$

$$d = \text{distance travelled in 1 sec.} = \frac{60 \times 10^3}{3600} = 16.67 \text{ m}$$

$$\therefore \text{Work done} = 19620 \times 16.67 = 327065.4 \text{ J}$$

$$\therefore \text{Power required by load} = \frac{\text{Work done}}{\text{time}} = \frac{327065.4}{1 \text{ sec}} = 327065.4 \text{ W}$$

$$P_{\text{out}} = \text{Power required by load} = 327065.4 \text{ W}$$

$$\text{Now, } \eta = \frac{P_{\text{out}}}{P_{\text{in}}}$$

$$\therefore P_{\text{in}} = \frac{P_{\text{out}}}{\eta} = \frac{327065.4}{0.7} = 467236.2857 \text{ W}$$

$$\text{But, } P_{\text{in}} = V \times I \text{ i.e. } 467236.2857 = 11 \times 10^3 \times I$$

$$\therefore I = 42.476 \text{ A}$$

► **Example 1.26 :** An aluminium kettle weighs 2.8 kg and holds 2750 cm³ of water. When connected to 220 V supply, its heater element takes current of 10 A. The efficiency of the kettle is given as 75%. Find the time required to boil the water from the initial temperature of 27 °C. Assume specific heat capacity of water and aluminium as 4200 J/kg °K and 950 J/kg °K respectively. (Dec. - 97)

Solution : Mass of kettle $m_k = 2.8 \text{ kg}$ and Mass of water $m = 2750 \text{ cm}^3$

$$\text{Now } 1 \text{ m}^3 \text{ water} = 1000 \text{ kg}$$

$$\therefore m = 2750 \times 10^{-6} \times 1000 = 2.75 \text{ kg}$$

$$\text{Specific heat of kettle } C_k = 950 \text{ J/kg } ^\circ\text{K}$$

$$\text{Specific heat of water } C = 4200 \text{ J/kg } ^\circ\text{K}$$

Heat required to raise temperature of water

$$= m C \Delta t = 2.75 \times 4200 \times (100 - 27)$$

$$= 843150 \text{ J}$$

$$\text{Heat lost in heating the kettle} = m_k C_k \Delta t = 2.8 \times 950 \times (100 - 27) = 194180 \text{ J}$$

$$\therefore \text{Total heat required} = 843150 + 194180 = 1037330 \text{ J}$$

$$\text{The efficiency } \eta = 75 \%$$

$$\therefore \text{Heat input} = \frac{\text{Heat output}}{\eta} = \frac{1037330}{0.75} = 1383106.7 \text{ J}$$

$$\text{Power input} = V \times I = 220 \times 10 = 2200 \text{ W}$$

$$\text{Now } P = \frac{\text{total heat input}}{\text{time required}}$$

$$\therefore 2200 = \frac{1383106.7}{\text{time}}$$

$$\therefore \text{time} = 628.68 \text{ sec} = 10 \text{ min and } 28.68 \text{ sec.}$$

► **Example 1.27 :** A fully charged car battery can give 200 Wh of energy for operating starting mechanism. At each start, the engine has to be cranked at 50 r.p.m. for 10 seconds, against a torque of 50 N-m. Assume overall efficiency of 40 % of the machine, estimate the number of starts before the battery is required to be recharged.

Solution : For 1 start, $N = 50 \text{ r.p.m.}$

$$\text{i.e. } \omega = \frac{2\pi N}{60} = 5.2359 \text{ rad/sec.}$$

$$\text{Torque } T = 50 \text{ N-m}$$

$$\therefore \text{Output of 1 start} = T \times \omega = 261.799 \text{ watt-sec i.e. J}$$

$$\text{Efficiency} = 40 \%$$

$$\therefore \text{Input power required for 1 start} = \frac{\text{output}}{\eta} = \frac{261.799}{0.4}$$

$$= 654.498 \text{ watt-sec i.e. J}$$

$$\therefore \text{Energy for 1 start} = \text{power} \times \text{time} = 654.498 \times 10$$

$$= 6544.98 \text{ joules i.e. watt-sec}$$

$$\text{Total energy battery can give} = 200 \text{ Wh.}$$

$$\therefore \text{Energy required for 1 start} = 6544.98 \text{ watt-sec}$$

$$= \frac{6544.98}{3600} \text{ watt-hour i.e. Wh} = 1.81 \text{ Wh.}$$

$$\therefore \text{Number of starts} = \frac{\text{Total energy}}{\text{Energy for 1 start}} = \frac{200 \text{ Wh}}{1.81 \text{ Wh}} = 110.497$$

\therefore Number of starts are approximately 111.

►► **Example 1.28 :** An electric furnace is used in order to melt 50 kg of tin per hour. Melting temperature of tin is 235 °C and room temperature is 15 °C. Latent heat of fusion for tin is 13.31 kcal/kg. Specific heat of tin is 0.055 kcal/kg°C. If input to furnace is 5 kW, find the efficiency of the furnace. (Dec-2005)

Solution : $m = 50 \text{ kg}$, $t_1 = 15 \text{ }^\circ\text{C}$, $t_2 = 235 \text{ }^\circ\text{C}$, $L = 13.31 \text{ kcal/kg}$
 $C = 0.055 \text{ kcal/kg}^\circ\text{C}$, $P_{in} = 5 \text{ kW}$

The melting takes place in two steps :

1. Heat required to raise temperature from 15 °C to 235 °C = $m C \Delta t$
2. Latent heat required to convert solid state to liquid state = mL

$$\therefore H = \text{heat output required} = m C \Delta t + mL$$

$$= 50 \times 0.055 \times (235 - 15) + 50 \times 13.31 = 1270.5 \text{ kcal}$$

Now $1 \text{ cal} = 4.2 \text{ J}$

$$\therefore H = 1270.5 \times 10^3 \times 4.2 \text{ J} = 5336.1 \text{ kJ}$$

time = 1 hour = 3600 sec

$$\therefore P_{out} = \frac{H \text{ (output)}}{\text{time}} = \frac{5336.1 \times 10^3}{3600} = 1482.25 \text{ W}$$

While $P_{in} = 5 \text{ kW}$

$$\therefore \% \eta = \frac{P_{out}}{P_{in}} \times 100 = \frac{1482.25}{5 \times 10^3} \times 100 = 29.645 \%$$

►► **Example 1.29 :** A motor drives a load torque of 200 N-m at 750 r.p.m. drawing 18 kW from mains. Assuming temperature to remain constant and 1 joule equal 0.2392 cal, determine, i) efficiency of motor and ii) losses per minute in kcal

Solution : $T = 200 \text{ Nm}$, $N = 750 \text{ r.p.m.}$, $P_{in} = 18 \text{ kW}$

$$P_{out} = T \times \omega = T \times \frac{2\pi N}{60} = \text{output of motor}$$

$$= \frac{200 \times 2\pi \times 750}{60} = 15.70796 \text{ kW}$$

$$\therefore \% \eta = \frac{P_{out}}{P_{in}} \times 100 = \frac{15.70796}{18} \times 100 = 87.26 \%$$

$$\text{Losses} = P_{in} - P_{out} = 18 \times 10^3 - 15.70796 \times 10^3 = 2292.04 \text{ W}$$

Losses in 1 minute = $2292.04 \times (60 \text{ sec}) = 137522.4 \text{ J}$

Now $1 \text{ J} = 0.2392 \text{ cal}$

$$\therefore \text{Losses/min} = 137522.4 \times 0.2392 = 32.8953 \text{ kcal}$$

These losses appear in the form of heat.

► **Example 1.30 :** Given below are the different electric appliances used by a family, their ratings and number of hours they are used daily.

Sr. No.	Appliance	Number	Rating	Hours (daily)
1	Tube lights	4	40 W each	5 hours, each
2	Bulbs	2	15 W each	6 hours, each
		1	40 W	2 hours.
3	Geyser	1	2 kW	1 hour.
4	Fans	3	60 W each	8 hours, each
5	Television	1	100 W	4 hours.

Find the electric bill per month if cost per unit (1 kWh) is 75 paise.
(Assume 30 days month)

Solution : First calculate daily consumption of each appliance in watt hours.

Appliance	Energy consumption in watt-hour
Tube lights	$4 \times 40 \times 5 = 800$
Bulbs	$2 \times 15 \times 6 = 180$
	$1 \times 40 \times 2 = 80$
Geyser	$1 \times 2000 \times 1 = 2000$
Fans	$3 \times 60 \times 8 = 1440$
Television	$1 \times 100 \times 4 = 400$
	Total = 4900 Wh = 4.9 kWh

$$\therefore \text{Monthly energy consumption} = 4.9 \times 30 \\ = 147 \text{ kWh} = 147 \text{ units.}$$

$$\therefore \text{Monthly bill} = 147 \times (0.75) = \text{Rs. } 110.25$$

► **Example 1.31 :** In a hydroelectric generating station the difference in level (head) between the water surface and turbine driving the generators is 425 meters. If 1250 liters of water is required to generate 1 kWh of electric energy. Find the overall efficiency.

Solution : 1 litre of water = 1 kg of water

$$\therefore m = 1250 \text{ kg, } h = 425 \text{ m}$$

$$\text{Energy produced by water} = mgh = 1250 \times 9.81 \times 425 = 5.21156 \times 10^6 \text{ J}$$

$$\therefore \text{Energy produced in 1 hour by water} = \frac{5.21156 \times 10^6}{3600} = 1447.6563 \text{ Wh}$$

$$= 1.44765 \text{ kWh}$$

$$\text{While actual generation} = 1 \text{ kWh}$$

$$\therefore \text{Efficiency} = \frac{1}{1.44765} \times 100 = 69.077 \%$$

► **Example 1.32 :** An electrically driven pump motor lifts 80 m^3 of water per minute through a height of 12 m. Efficiencies of motor and pump are 70 % and 80 % respectively.

Calculate,

i) Current drawn by motor if it works on 400 volts supply.

ii) Energy consumption in kWh and cost of the energy at the rate of 75 paise/kWh, if pump operates 2 hours per day for 30 days.

Assume 1 m^3 of water = 1000 kg

(Dec.-2006)

Solution : The given values are,

$$m = 80 \text{ m}^3 = 80 \times 1000 \text{ kg, } h = 12 \text{ m, } \text{time} = 1 \text{ minute}$$

The arrangement is shown in the Fig. 1.50.

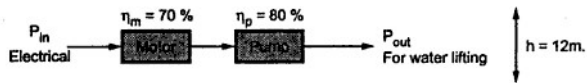

Fig. 1.50

$$P_{\text{out}} = mgh = 80 \times 1000 \times 9.81 \times 12 = 9.4176 \times 10^6 \text{ J}$$

$$\therefore P_{\text{out in watts}} = \frac{P_{\text{out in J}}}{\text{Time}} = \frac{9.4176 \times 10^6}{60} \quad \dots \text{time} = 1 \text{ min} = 60 \text{ sec}$$

$$= 156.96 \times 10^3 \text{ watts}$$

$$\therefore P_{\text{in}} = \frac{P_{\text{out}}}{\eta_m \times \eta_p} = \frac{156.96 \times 10^3}{0.7 \times 0.8} = 280.2857 \times 10^3 \text{ watts}$$

$$\text{But } P_{\text{in}} = VI \text{ i.e. } 280.2857 \times 10^3 = 400 \times I$$

$$i) \therefore I = 700.714 \text{ A}$$

$$\begin{aligned} ii) \text{ Daily energy consumption} &= VI t \quad \text{where } t = 2 \text{ hours per day} \\ &= 400 \times 700.714 \times 2 = 560.5712 \times 10^3 \text{ Wh} \\ &= 560.5712 \text{ kWh} \end{aligned}$$

$$\therefore \text{ Monthly consumption} = 560.5712 \times 30 = 16817.136 \text{ kWh}$$

$$\begin{aligned} \therefore \text{ cost of energy} &= 16817.136 \times \text{rate per kWh} = 16817.136 \times 0.75 \\ &= \text{Rs. } 12612.85 \end{aligned}$$

► **Example 1.33 :** An electric boiler has two heating elements each of 200 V, 4 kW rating. Boiler contains 20 litres of water at 20 °C. Assuming 8 % loss of heat from boiler, find the time required after switching on the boiler to heat the water up to 90 °C if

a) two elements are in parallel and b) two elements are in series

Specific heat capacity of water is 4180 J/kg°C. Assume supply voltage as 200 V.

Solution : Mass of water = 20 litres = 20 kg

$$\Delta t = t_2 - t_1 = 90 - 20 = 70 \text{ °C} = 70 \text{ °K}$$

Heat energy required,

$$H = m C \Delta t = 20 \times 70 \times 4180 = 5.852 \times 10^6 \text{ J}$$

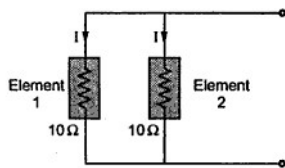

Fig. 1.51

a) Elements are in parallel :

Voltage across each element = 200 V

$$\begin{aligned} \text{Resistance of each} &= \frac{V^2}{P} = \frac{(200)^2}{4000} \\ &= 10 \text{ } \Omega \end{aligned}$$

I = current by each element

$$= \frac{V}{R} = \frac{200}{10} = 20 \text{ A}$$

$$\begin{aligned} \therefore \text{ Power by each element} &= I^2 R \\ &= (20)^2 \times 10 = 4 \text{ kW} \end{aligned}$$

$$\therefore \text{ Total power absorbed} = 2 \times 4 = 8 \text{ kW}$$

$$\therefore \text{ Total input energy} = \text{power} \times \text{time} = 8000 t \text{ J}$$

Let 't' be time required to raise the temperature of water.

But there are 8 % losses i.e. $\eta = 92 \%$

\therefore Net heat energy required to raise the temperature

$$= \frac{H}{0.92} = 6.36086 \times 10^6 \text{ J}$$

$$\therefore 6.36086 \times 10^6 = 8000 t$$

$$\therefore t = 795.1087 \text{ sec.} = 13.25 \text{ min.}$$

b) Elements in series :

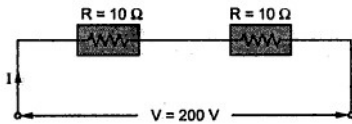

Fig. 1.52

Net heat energy required to raise the temperature of water due to losses remains same i.e. 6.36086×10^6 J.

But let us see how much energy can be absorbed when elements are in parallel.

$$\therefore \text{Total resistance due to series} = R_1 + R_2 = 2R = 20 \Omega$$

$$\therefore \text{Total current drawn} = \frac{V}{R_{eq}} = \frac{200}{20} = 10 \text{ A}$$

$$\therefore \text{Power by each element} = I^2 R = (10)^2 \times 10 = 1 \text{ kW}$$

$$\therefore \text{Total power drawn} = 2 \times \text{power by each} = 2 \text{ kW}$$

$$\therefore \text{Total energy absorbed in time 't' sec}$$

$$\text{power} \times \text{time} = 2000 t \text{ J}$$

$$\therefore 2000 t = 6.36086 \times 10^6$$

$$\therefore t = 3180.43 \text{ sec} = 53 \text{ min}$$

► **Example 1.34 :** The level difference (head) between water surface and turbine at hydroelectric generating station is 500 m. The capacity of station is of 250 MW and it supplies a full load for 8 hours a day. Overall efficiency of station is 90 %. Find how much volume of water is used, daily.

Solution : It is connected to full load i.e.

$$P_{out} = 250 \text{ MW} = 250 \times 10^6 \text{ watt i.e. J/sec}$$

$$\therefore \text{Energy output in 8 hours} = 250 \times 10^6 \times (8 \times 3600) = 7.2 \times 10^{12} \text{ J}$$

$$\text{Potential energy of water} = m g h = m \times 9.81 \times 500 \text{ J}$$

This must supply the energy input required for driving a load.

$$\therefore \text{Input energy} = \frac{\text{output}}{\text{efficiency}} = \frac{7.2 \times 10^{12}}{0.9} = 8 \times 10^{12} \text{ J}$$

$$\therefore 8 \times 10^{12} = m \times 9.81 \times 500$$

$$\therefore m = 1.6309 \times 10^9 \text{ kg}$$

$$\text{Now } 1 \text{ m}^3 \text{ of water} = 1000 \text{ kg}$$

$$\therefore 1.6309 \times 10^9 \text{ kg} = 1.6309 \times 10^6 \text{ m}^3$$

$$\therefore \text{Volume of water daily consumed is } 1.6309 \times 10^6 \text{ m}^3.$$

► **Example 1.35 :** A locomotive when driving a load $30 \times 10^3 \text{ kg}$ requires an output of 60 H.P. Load is moving up an incline of 2 in 100. The frictional resistance is 300 kg. The gearing efficiency of 80 % and motor efficiency is 90 %. Calculate the speed at which load is moving and current drawn by the motor if connected to 500 V mains.

$$\text{Assume } 1 \text{ H.P.} = 735.5 \text{ W.}$$

Solution : mass of load = $30 \times 10^3 \text{ kg}$, slope 2 in 100, friction = 300 kg

$$\eta_g = 80 \%, \quad \eta_m = 90 \%, \quad V = 500 \text{ V}$$

$$w = \text{Weight of load} = m \times g = 30 \times 10^3 \times 9.81 = 294300 \text{ N}$$

The various forces acting on the locomotive are shown in the Fig. 1.53.

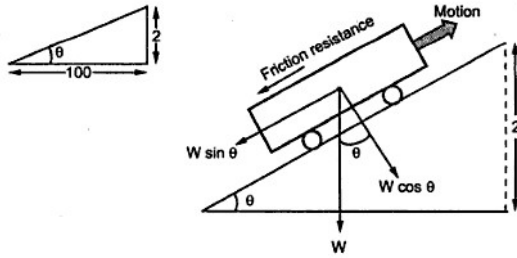

Fig. 1.53

The components opposite to motion are,

1. Friction resistance = $300 \times 9.81 = 2943 \text{ N}$

2. Component of weight opposite to motion = $W \sin \theta$

$$= 294300 \times \frac{2}{100} = 5886 \text{ N}$$

Remember that for small values of θ , $\sin \theta = \tan \theta = \frac{2}{100}$

$$\therefore \text{Total resistance} = 2943 + 5886 = 8829 \text{ N}$$

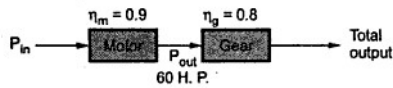

Fig. 1.54

$$P_{\text{out}} = \text{output of motor} = 60 \text{ H.P.} = 60 \times 735.5 = 44130 \text{ W}$$

$$\therefore P_{\text{in}} = \frac{P_{\text{out}}}{\eta_m} = \frac{44130}{0.9} = 49033.33 \text{ W}$$

But $P_{\text{in}} = V I$

$$\therefore 49033.33 = 500 \times I$$

$$\therefore I = 98.067 \text{ A} \quad \dots \text{ current drawn}$$

$$\text{Total output} = P_{\text{out}} \times \eta_g = 44130 \times 0.8 = 35304 \text{ W}$$

$$\therefore \text{Total output energy} = \text{Total output} \times 1 \text{ sec} \quad \text{joules} \quad \dots \text{ as } 1 \text{ W} = 1 \text{ J/sec}$$

$$= 35304 \text{ J}$$

$$\text{Opposing force} = 8829 \text{ N}$$

$$\begin{aligned} \text{Work done} &= \text{work done in overcoming opposition} \\ &= \text{opposing force} \times \text{distance travelled in 1 sec} \\ &= 8829 \times d \quad \text{J} \end{aligned}$$

$$\therefore 35304 = 8829 \times d$$

$$\therefore d = 3.9986 \text{ m in 1 sec}$$

$$\therefore \text{Speed of load} = 3.9986 \text{ m/sec} = \frac{3.9986 \times 3600}{1000} \text{ kmph} = 14.39 \text{ kmph}$$

► **Example 1.36 :** An electric lift makes 20 double journeys per hour. A load of 8 tonne is raised by it through a height of 60 m and it returns empty. The lift takes 80 sec to go up and 70 sec to return. The weight of cage is 1 tonne and that of counter weight 2500 kg. The efficiency of hoist is 75 % and of motor is 80 %. Find the energy consumption for 1 hour in kWh and power output rating of motor.

Solution : The up and down journeys are shown in the Fig. 1.55 (a) and (b).

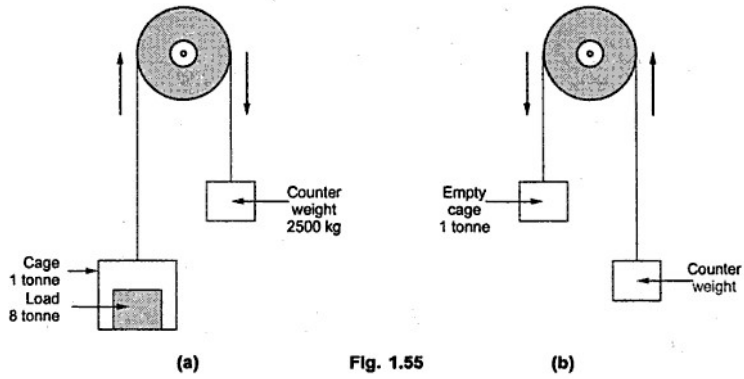

Fig. 1.55

i) During upward journey,

$$\text{Net mass} = \text{mass of load} + \text{mass of cage} - \text{counter weight}$$

$$= 8 \times 10^3 + 1 \times 10^3 - 2500 = 6500 \text{ kg}$$

$$\therefore \text{Net weight} = 6500 \times 9.81 = 63765 \text{ N}$$

$$h = 60 \text{ m}$$

$$\therefore \text{Work done} = mgh = 63765 \times 60 = 3.8259 \times 10^6 \text{ J}$$

ii) During downward journey,

$$\text{Net mass} = \text{counter weight} - \text{mass of cage}$$

$$= 2500 - 1 \times 10^3 = 1500 \text{ kg}$$

$$\therefore \text{Work done} = mgh = 1500 \times 9.81 \times 60 = 882.9 \times 10^3 \text{ J}$$

Hence in a double journey i.e. upward and downward,

$$\text{Total work done} = 3.8259 \times 10^6 + 882.9 \times 10^3 = 4.7088 \times 10^6 \text{ J}$$

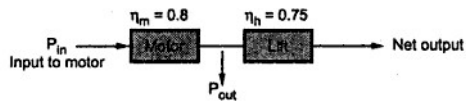

Fig. 1.56

In 1 hour lift completes 20 double journeys

$$\therefore \text{Total work done in 1 hour} = 4.7088 \times 10^6 \times 20 = 94.176 \times 10^6 \text{ J}$$

$$P_{\text{out}} = \text{Output of motor} = \frac{\text{Net output in 1 hour}}{\eta_h}$$

$$= \frac{94.176 \times 10^6}{0.75} = 125.568 \times 10^6 \text{ J in 1 hour}$$

$$\therefore P_{\text{in}} = \frac{P_{\text{out}}}{\eta_m} = \frac{125.568 \times 10^6}{0.8} = 156.96 \times 10^6 \text{ J in 1 hour}$$

$$\therefore \text{Hourly consumption is kWh} = \frac{156.96 \times 10^6}{3600 \times 1000} = 43.6 \text{ kWh}$$

Key Point : The power rating of motor depends on maximum power required out of two journeys i.e. upward or downward. The maximum is while upward journey, which decides power rating.

$$\therefore \text{Work done in upward journey} = 3.8259 \times 10^6 \text{ J}$$

$$\therefore P_{\text{out}} = \frac{\text{Work done}}{\eta_h} = \frac{3.8259 \times 10^6}{0.75} = 5.1012 \times 10^6 \text{ J}$$

Time required = 80 sec for upward journey

$$\therefore \text{Output rating} = \frac{P_{\text{out}}}{\text{time}} = \frac{5.1012 \times 10^6}{80} = 63765 \text{ watts}$$

$$= \frac{63765}{735.5} = 86.69 \text{ H.P.} \quad \dots 1 \text{ H.P.} = 735.5 \text{ W}$$

► **Example 1.37 :** A belt driven pulley of 0.1 m in radius rotates at a speed of 1500 revolutions per minute. The tension in the tight side is 35 kg. If it is producing output of 2 kW, calculate tension in the slack side of belt.

Solution :

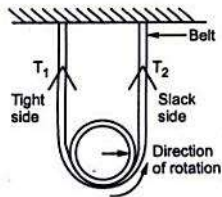

Fig. 1.57

Net tension acting on the pulley is difference between the two tensions,

$$\text{i.e. } F = (T_1 - T_2) \times 9.81 \text{ in N}$$

where T_1 and T_2 are in kg.

Torque produced = $F \times r$

Where r = radius of pulley

$$= (T_1 - T_2) \times 9.81 \times 0.1$$

$$= (35 - T_2) \times 0.981 \text{ N-m}$$

Now power produced,

$$P = T \times \omega$$

$$\therefore 2 \times 10^3 = (35 - T_2) \times 0.981 \times \frac{2\pi N}{60}$$

$$\text{as } \omega = \frac{2\pi N}{60} \quad \text{Where } N \text{ is speed in r.p.m.}$$

$$\therefore 2 \times 10^3 = (35 - T_2) \times 0.981 \times \frac{2 \times \pi \times 1500}{60}$$

$$\therefore T_2 = 22.02 \text{ kg.}$$

► **Example 1.38 :** Determine the power input necessary for an electric geyser to heat 8 litres of water from 25 °C to 75 °C in 10 min. Water equivalent of geyser is 150 grams. Heat lost in this period is 30 kJ. Find the efficiency of the geyser.

Solution : Mass of water = 8 litre = 8 kg, water equivalent of geyser = 150 gm

$$\Delta t = t_2 - t_1 = 75 - 25 = 50, \text{ Time} = 10 \text{ min} = 600 \text{ sec, Heat lost} = 30 \text{ kJ}$$

$$\text{Total mass } m = 8 + 0.150 = 8.150 \text{ kg}$$

$$\therefore \text{Heat required} = m C \Delta t = 8.150 \times 4190 \times 50 = 1.7074 \times 10^6 \text{ J}$$

Now Heat input = Heat required + Heat lost

$$= 1.7074 \times 10^6 + 30 \times 10^3 = 1.737425 \times 10^6 \text{ J}$$

$$\text{Power input} = \frac{\text{Heat input}}{\text{Time}} = \frac{1.737425 \times 10^6}{600} = 2895.7083 \text{ W}$$

Key Point : While calculating efficiency of geyser we must consider energy output required to heat water alone and not along with the geyser.

$$\therefore \text{useful output} = 8 \times 4190 \times 50 = 1.676 \times 10^6 \text{ J}$$

$$\therefore \text{Geyser } \eta = \frac{\text{useful output}}{\text{total input}} \times 100 = \frac{1.676 \times 10^6}{1.7374 \times 10^6} \times 100$$

$$= 96.465 \%$$

Key Point : Water equivalent of geyser means whatever heat is required to heat body of geyser can be considered to be equivalent to energy required to heat equivalent mass of water.

► **Example 1.39 :** Determine the horsepower rating of an electrical motor which is required to be coupled to a centrifugal pump provided to lift water in to over head tank. The tank capacity is 10 kilo ltrs. The tank's water head is 10 mtrs. The efficiencies of pump and motor, at operating conditions, are 65 % and 85 % respectively. The tank is required to be filled up fully in 15 minutes. Water head loss due to pipe friction is equivalent to 1.15 mtrs. Further if the over head water tank is required to be fully filled up twice a day, what shall be the monthly (30 days) electricity bill if the electricity charges are Rs. 3.50 per unit kWh ?

[Dec. - 2001]

Solution : $m = 10$ kilo litres = 10,000 lts = 10,000 kg, as 1 litre = 1 kg

$$g = 9.81 \text{ m/s}^2, \quad t = 15 \text{ min} = 900 \text{ sec}, \quad h = 10 \text{ m}$$

Water head loss due to pipe friction = 1.15 m

$$\therefore h_{\text{eff}} = 10 + 1.15 = 11.15 \text{ m}$$

Net work done = $mg h_{\text{eff}}$

$$P_{\text{out}} = \frac{\text{Net work done}}{t} = \frac{mg h_{\text{eff}}}{t} = \frac{10000 \times 9.81 \times 11.15}{900}$$

$$\text{Power output of pump} = 1215.35 \text{ W} = 1.2153 \text{ kW}$$

$$P_{\text{in to motor}} = \frac{\text{Power output of pump}}{\eta_{\text{pump}} \times \eta_{\text{motor}}} = \frac{1215.35}{0.65 \times 0.85}$$

$$= 2199.72 \text{ W} = 2.2 \text{ kW}$$

$$\text{Power output of motor} = \frac{\text{Power output of pump}}{\eta_{\text{pump}}}$$

$$= \frac{1.2153 \times 10^3}{0.65} = 1869.69 \text{ W}$$

$$\text{Horsepower rating of motor} = (1869.69) / 735.5 = 2.542 \text{ HP}$$

Input energy required = Power input to motor \times twice a day

$$= 2.2 \times 10^3 \times 2 = 4.4 \text{ kW}$$

$$\text{Total hrs required} = 2 \times 15 \text{ min} = 30 \text{ min} = \frac{1}{2} \text{ hrs}$$

$$\therefore \text{Total input} = 4.4 \text{ kW} \times \frac{1}{2} \text{ hrs} = 2.2 \text{ kWh daily}$$

Total electricity bill for month = Total input energy \times Number of days \times Rate of energy

$$= 2.2 \times 30 \times 3.50$$

$$\therefore \text{Monthly bill} = \text{Rs. 231}$$

► **Example 1.40 :** A three blade wind mill is used to lift underground water and store it at ground level using a pump. For average wind speeds the value of torque developed is 20 N-m and the speed of this wind mill is 150 r.p.m. Actual head of water is 9 m and pipe friction is 1 m headloss. The wind mill mechanical efficiency and water pump efficiency are 40 % and 75 % respectively. Calculate the run of this wind mill to store water quantity of 20 kilo litres at ground level. (May - 2003)

Solution : $T = 20 \text{ N-m}$, $N = 150 \text{ r.p.m.}$, $h_t = \text{total head} = 9 + 1 = 10 \text{ m}$

$$\eta_m = 40 \%, \eta_{\text{pump}} = 75 \%, m = 20 \text{ klitre} = 20 \times 10^3 \text{ litre}$$

$$P_{\text{in}} = T \times \omega \quad \text{Where} \quad \omega = \frac{2\pi N}{60} = \frac{20 \times 2\pi \times 150}{60}$$

$$= 314.1592 \text{ W}$$

$$\therefore P_{\text{out}} = P_{\text{in}} \times \eta_m \times \eta_{\text{pump}} = 314.1592 \times 0.4 \times 0.75$$

$$= 94.2477 \text{ W and } W = \text{J/sec}$$

So wind mill requires 1 sec to produce 94.2477 Joules. Now to lift 20×10^3 litres of water through 10 m it requires,

$$P_{\text{total}} = mgh_t \quad \text{Where } 1 \text{ litre} = 1 \text{ kg of water}$$

$$= (20 \times 10^3) \times 9.81 \times 10 = 1962000 \text{ J}$$

\therefore Time required by mill to produce P_{total} is,

$$t = \frac{P_{\text{total}}}{P_{\text{out}}} = \frac{1962000}{94.2477} = 20817.4841 \text{ sec} = \frac{20817.4841}{3600} \text{ hrs}$$

$$= 5.7826 \text{ hrs}$$

This is the required run of the mill.

► **Example 1.41 :** Three cells each having e.m.f. of 1.6 V and internal resistance 1.1 Ω are connected in (i) series and (ii) parallel, to a resistance of 2.5 Ω . Find in each case,

a) Current b) p.d. across the external resistance c) power wasted in the external resistance.

Solution : Case i) Series connection

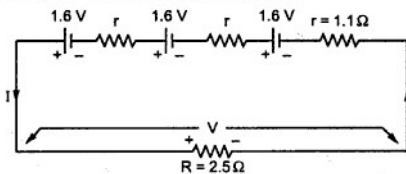

Fig. 1.58

Total e.m.f. = 3 \times e.m.f. of each cell

$$E_T = 3 \times 1.6 = 4.8 \text{ V}$$

Total resistance of circuit

$$R_T = 3r + R$$

$$= 3 \times 1.1 + 2.5$$

$$= 5.8 \Omega$$

$$\therefore \text{a) } I = \frac{E_T}{R_T} = \frac{4.8}{5.8} = 0.8275 \text{ A}$$

$$\text{b) } V = \text{p.d. across } R = I \times R = 0.8275 \times 2.5 = 2.0689 \text{ V}$$

$$\text{c) } P = I^2 R = (0.8275)^2 \times 2.5 = 1.7118 \text{ W}$$

Case (ii) : Parallel connection

In equivalent form, when batteries are in parallel, the total internal resistance is

$$r' = \frac{r}{n} \text{ Where } n = \text{number of cells in parallel}$$

$$= \frac{1.1}{3} = 0.3666 \Omega$$

$$\text{a) } \therefore I = \frac{E}{R+r'} = \frac{1.6}{2.5+0.366} = 0.55814 \text{ A}$$

$$\text{b) } V = I \times R = 0.55814 \times 2.5 = 1.3953 \text{ V}$$

$$\text{c) } P = I^2 R = (0.55814)^2 \times 2.5 = 0.7788 \text{ W}$$

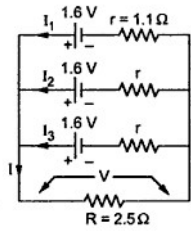

Fig. 1.59

Example 1.42 : When a resistance of 2 Ω is placed across the terminals of battery, the current is 2 A. When the resistance is increased to 5 Ω, the current falls to 1 A. Find e.m.f. of battery and its internal resistance.

Solution : The two cases are shown in the Fig. 1.60.

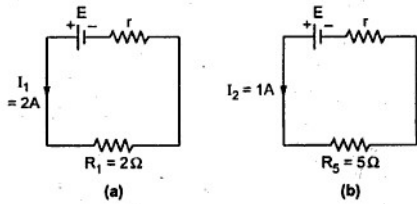

Fig. 1.60

$$\text{Now } I_1 = \frac{E}{R_1+r} \text{ i.e. } E = 2 [2 + r] = 4 + 2r \quad \dots(1)$$

$$\text{and } I_2 = \frac{E}{R_2+r} \text{ i.e. } E = 1 [5 + r] = 5 + r \quad \dots(2)$$

Subtracting (2) from (1),

$$0 = -1 + r \text{ i.e. } r = 1 \Omega$$

and $E = 6 \text{ V}$

►► **Example 1.43 :** A bucket contains 15 - litres of water at 20 °C. A 2-kW immersion heater is used to raise the temperature of water to 95 °C. The overall efficiency of the process is 90 %, and the specific heat capacity of water is 4187 J/kg °K. Find the time required for the process. [Dec-2003]

Solution : $m = 15 \text{ kg}$, 1 litre = 1 kg of water, $C = 4187 \text{ J/kg } ^\circ\text{K}$

$$t_1 = 20 \text{ } ^\circ\text{C}, t_2 = 95 \text{ } ^\circ\text{C}, P_{in} = 2 \text{ kW}, \eta = 90 \%$$

Energy required to heat the water is the output energy.

$$\therefore \text{Output energy} = mC \Delta t = 15 \times 4187 \times (95 - 20) = 4.7103 \times 10^6 \text{ J}$$

$$\text{Input energy} = \frac{\text{output}}{\eta} = \frac{4.7103 \times 10^6}{0.9} = 5.2337 \times 10^6 \text{ J}$$

$$P_{in} = \frac{\text{input in J}}{\text{time in sec}}$$

$$\therefore 2 \times 10^3 = \frac{5.2337 \times 10^6}{\text{time}}$$

$$\therefore \text{time} = 2616.875 \text{ sec} = 43.614 \text{ minutes}$$

►► **Example 1.44 :** At 0 °C, a specimen of copper wire has its resistance equal to 4-milliohm and its temperature coefficient of resistance equal to (1 / 234.5) per °C. Find the values of its resistance and temperature coefficient of resistance at 70 °C. [Dec.-2003]

Solution : $R_0 = 4 \text{ m}\Omega$, $\alpha_0 = \frac{1}{234.5} / ^\circ\text{C}$

$$\alpha_t = \frac{\alpha_0}{1 + \alpha_0 t}$$

$$\therefore \alpha_{70} = \frac{(1 / 234.5)}{1 + \frac{1}{234.5} \times 70} = 0.003284 / ^\circ\text{C} \text{ at } 70 \text{ } ^\circ\text{C}$$

$$\text{Now } R_t = R_0 (1 + \alpha_0 t) = 4 \left[1 + \frac{1}{234.5} \times 70 \right] = 5.194 \text{ m}\Omega \text{ at } 70 \text{ } ^\circ\text{C}$$

►► **Example 1.45 :** An electric pump lifts 12 m³ of water per minute to a height of 15-m. If its overall efficiency is 60%, find the input power. If the pump is used for 4-hours a day, find the daily cost of energy at Rs. 2.25 per unit. [Dec-2003]

Solution :

Key Point : 1 m^3 of water = 1000 kg = 1 tonne

$$m = 12\text{ m}^3 = 12 \times 1000\text{ kg as } 1\text{ m}^3 \text{ of water} = 1000\text{ kg, } h = 15\text{ m, } \eta = 60\%, \\ \text{time} = 1\text{ minute} = 60\text{ sec}$$

$$\text{Energy output} = mgh = 12 \times 1000 \times 9.81 \times 15 = 1.7658 \times 10^6\text{ J}$$

$$\text{Energy input} = \frac{\text{output}}{\eta} = \frac{1.7658 \times 10^6}{0.6} = 2.943 \times 10^6\text{ J i.e. watt-sec}$$

$$\text{time for lifting} = 1\text{ minute} = 60\text{ sec}$$

$$\therefore P_{\text{in}} = \frac{\text{input}}{\text{time}} = \frac{2.943 \times 10^6}{60} = 49.05\text{ kW}$$

$$\text{For 4 hours, pump consumes } P_{\text{in}} \times 4 = 196.2\text{ kWh}$$

$$\text{Thus total units per day} = 196.2$$

$$\therefore \text{Daily cost} = 196.2 \times 2.25 = \text{Rs. } 441.45$$

► **Example 1.46 :** An electric pump lifts 60 m^3 of water per hour to a height of 25 m. The pump efficiency is 82 % and the motor efficiency is 77 %. The pump is used for 3 hours daily. Find the energy consumed per week, if the mass of 1 m^3 of water is 1000 kg.

[May-2004]

Solution : $1\text{ m}^3 = 1000\text{ kg}$ hence $m = 60\text{ m}^3 = 60000\text{ kg}$

$$h = 25\text{ m, } \eta_m = 77\%, \eta_p = 82\%, \text{time} = 1\text{ hour} = 3600\text{ sec}$$

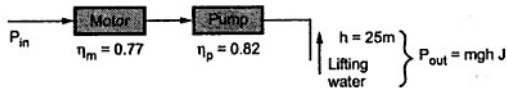

Fig. 1.61

$$P_{\text{out}} = mgh = 60000 \times 9.81 \times 25 = 14.715 \times 10^6\text{ J}$$

$$P_{\text{out in watts}} = \frac{P_{\text{out in J}}}{\text{time}} = \frac{14.715 \times 10^6}{3600} = 4087.5\text{ W}$$

$$\therefore P_{\text{in}} = \frac{P_{\text{out}}}{\eta_m \times \eta_p} = \frac{4087.5}{0.77 \times 0.82} = 6473.7092\text{ W}$$

Per day 3 hours running hence,

$$\text{Daily consumption} = 6473.7092 \times 3 = 19.421\text{ kWh}$$

$$\therefore \text{Weekly power consumption} = 7 \times 19.421 = 135.947\text{ kWh}$$

$$\therefore \text{Weekly energy consumption} = 135.947 \times 10^3 \times 3600 = 489.4124 \times 10^6\text{ J}$$

►► **Example 1.47 :** A single-core cable has its conductor diameter as 1.5 cm and outer diameter as 3.9 cm. The resistivities of conductor and insulator are 1.73×10^{-8} ohm-m and 8×10^{12} ohm-m respectively. Find, for a cable length of 100 m, its insulation resistance and the resistance of conductor. [May-2004]

Solution : $D_1 = 1.5$ cm, outer diameter = 3.9 cm, $\rho_c = 1.73 \times 10^{-8} \Omega \text{ m}$,
 $\rho_i = 8 \times 10^{12} \Omega \text{ m}$, $l = 100$ m

$$\text{For conductor, } R = \frac{\rho_c l}{a}$$

$$\text{and } a = \frac{\pi}{4} D_1^2 = \frac{\pi}{4} \times (1.5 \times 10^{-2})^2 = 1.767 \times 10^{-4} \text{ m}^2$$

$$\therefore R = \frac{1.73 \times 10^{-8} \times 100}{1.767 \times 10^{-4}} = 9.7897 \times 10^{-3} \Omega$$

$$\text{For insulation, } R_1 = \frac{D_1}{2} = 0.75 \text{ cm}$$

$$R_2 = R_1 + t \quad \text{Where } t = \frac{D_2 - D_1}{2} = 1.2 \text{ cm}$$

$$= 0.75 + 1.2 = 1.95 \text{ cm}$$

$$\therefore R_i = \frac{\rho_i}{2 \pi l} \ln \left(\frac{R_2}{R_1} \right) = \frac{8 \times 10^{12}}{2 \pi \times 100} \ln \left(\frac{1.95}{0.75} \right)$$

$$= 1.2165 \times 10^{10} \Omega$$

►► **Example 1.48 :** Two coils connected in series have resistances of 600 Ω and 400 Ω with temperature coefficient of 0.1 % and 0.4 % respectively at 20 $^{\circ}\text{C}$. Find the effective temperature coefficient of series combination at 20 $^{\circ}\text{C}$. When the combination is heated to 50 $^{\circ}\text{C}$, find the resistance of the series combination. [Dec-2004]

Solution : $R_1 = 600 \Omega$, $R_2 = 400 \Omega$, $\alpha_1 = 0.1 \% = \frac{0.1}{100}$ and $\alpha_2 = 0.4 \% = \frac{0.4}{100}$

All values given at $t_1 = 20^{\circ}\text{C}$.

Let R'_1 and R'_2 are resistance values at $t_2^{\circ}\text{C}$

$$R'_1 = R_1 [1 + \alpha_1 (t_2 - t_1)] \quad \text{and} \quad R'_2 = R_2 [1 + \alpha_2 (t_2 - t_1)]$$

At $t_1^{\circ}\text{C}$, $R_{12} = R_1 + R_2$ and at $t_2^{\circ}\text{C}$, $R'_{12} = R'_1 + R'_2$

While $R'_{12} = R_{12} [1 + \alpha_{12} (t_2 - t_1)]$

Where α_{12} = R.T.C. of series combination at $t_1^{\circ}\text{C}$

$$\therefore R'_1 + R'_2 = (R_1 + R_2) [1 + \alpha_{12} (t_2 - t_1)]$$

$$\therefore R_1 [1 + \alpha_1 (t_2 - t_1)] + R_2 [1 + \alpha_2 (t_2 - t_1)] = (R_1 + R_2) [1 + \alpha_{12} (t_2 - t_1)]$$

$$\text{Simplifying, } \alpha_{12} = \frac{R_1 \alpha_1 + R_2 \alpha_2}{R_1 + R_2} \quad \dots \text{ Refer section 1.11.5}$$

$$= \frac{\left[600 \times \left(\frac{0.1}{100} \right) \right] + \left[400 \times \left(\frac{0.4}{100} \right) \right]}{600 + 400} = 2.2 \times 10^{-3} / ^\circ\text{C}$$

$$\text{Now } R_{12} = R_1 + R_2 = 600 + 400 = 1000 \Omega \text{ at } t_1 = 20^\circ\text{C}$$

$$\begin{aligned} \therefore R'_{12} &= \text{resistance of series combination at } t_2 = 50^\circ\text{C} \\ &= R_{12} [1 + \alpha_{12} (t_2 - t_1)] = 1000 [1 + 2.2 \times 10^{-3} (50 - 20)] \\ &= 1066 \Omega \end{aligned}$$

Note : Alternatively find R'_1 and R'_2 at 50°C and $R'_{12} = R'_1 + R'_2$

► **Example 1.49 :** The effective head of 100 MW power station is 220 m. Station supplies full load for 12 hours a day. The overall efficiency of power station is 86.4 %. Find the volume of water used. [Dec-2004]

Solution : $h = 220 \text{ m}$, Full load output $P_{\text{out}} = 100 \text{ MW} = 100 \times 10^6 \text{ W}$

$$t = 12 \text{ hours, } \eta = 86.4 \%, P_{\text{out}} = 100 \times 10^6 \text{ W i.e. J/sec}$$

$$\begin{aligned} \therefore \text{Energy output for full load} &= P_{\text{out}} \times \text{hours per day} = 100 \times 10^6 \times 12 = 1200 \times 10^6 \text{ Wh} \\ &= 1200 \times 10^6 \times 3600 \text{ J} = 4.32 \times 10^{12} \text{ J} \end{aligned}$$

$$\therefore \text{Input energy} = \frac{\text{Energy output}}{\eta} = \frac{4.32 \times 10^{12}}{0.864} = 5 \times 10^{12} \text{ J}$$

This is potential energy of water mgh.

$$\therefore \text{P.E. of water} = \text{Input energy supplied}$$

$$\therefore m \times g \times h = 5 \times 10^{12}$$

$$\therefore m = \frac{5 \times 10^{12}}{9.81 \times 220} = 2.3167 \times 10^9 \text{ kg}$$

$$\text{But } 1 \text{ m}^3 \text{ of water} = 1000 \text{ kg}$$

$$\therefore \text{volume of water used} = \frac{2.3167 \times 10^9}{1000} \text{ m}^3 = 2.3167 \times 10^6 \text{ m}^3$$

► **Example 1.50 :** An electric furnace is used to melt aluminium. Initial temperature of the solid aluminium is 32°C and its melting point is 680°C . Specific heat capacity of aluminium is $0.95 \text{ kJ/kg}^\circ\text{C}$, and the heat required to melt 1 kg of aluminium at its melting point is 450 kJ . If the input power drawn by the furnace is 20 kW and its overall efficiency is 60% , find the mass of aluminium melted per hour. [May-2005]

Solution : $t_1 = 32\text{ }^\circ\text{C}$, $t_2 = 680\text{ }^\circ\text{C}$, $C = 0.95\text{ kJ/kg}^\circ\text{K}$, $P_{in} = 20\text{ kW}$, $\eta = 60\% = 0.6$

Heat required to melt 1 kg of Al at melting point is 450 kJ is the information related to Latent Heat.

$$\text{Total heat} = \text{sensible heat} + \text{Latent heat} = m C \Delta t + mL$$

Where $L = 450\text{ kJ/kg}$ as given

$$\begin{aligned} \therefore \text{Total output energy} &= m [C \Delta t + L] = m [0.95 \times (680 - 32) + 450] \\ &= m \times 1.0656 \times 10^3\text{ kJ} \dots \text{Note both C and L in kJ} \end{aligned}$$

$$P_{in} = 20\text{ kW}$$

and time = 1 hour as mass of Al per hour to be obtained

$$\therefore \text{Input energy} = P_{in} \times \text{time} = 20 \times 10^3 \times 3600 = 72 \times 10^6\text{ J}$$

$$\therefore \text{Output energy} = \text{Input} \times \eta = 72 \times 10^6 \times 0.6 = 43.2 \times 10^6\text{ J} = 43.2 \times 10^3\text{ kJ}$$

Equating with total output energy required,

$$m \times 1.0656 \times 10^3 = 43.2 \times 10^3$$

$$\therefore m = 40.5405\text{ kg aluminium per hour will be melted}$$

Example 1.51 : Show how four cells, each rated 1.5 V, 0.1 A, can be connected as batteries in three different ways to obtain different voltage and current ratings. State the voltage and current ratings of each type. [May-2005]

Solution : The three ways in which cells can be connected are,

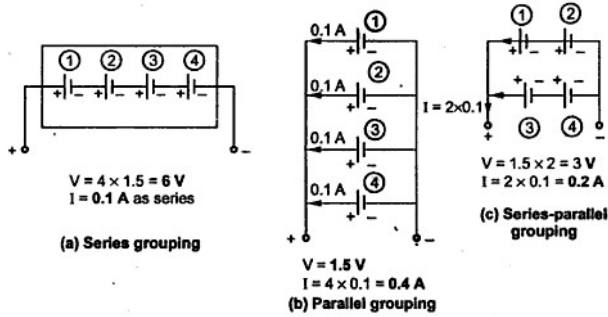

Fig. 1.62

►► Example 1.52 : At 0 °C, the resistances and their temperature coefficients of resistance of two resistors 'A' and 'B' are 80 ohm and 120 ohm, and 0.0038 per °C and 0.0018 per °C, respectively. Find the temperature-coefficient of resistance at 0 °C of their series combination.

[May-2005]

Solution : At 0° C, $R_1 = 80 \Omega$, $R_2 = 120 \Omega$, $\alpha_1 = 0.0038 / ^\circ\text{C}$, $\alpha_2 = 0.0018 / ^\circ\text{C}$

Refer section 1.11.5,

$$\alpha_{12} = \frac{R_1\alpha_1 + R_2\alpha_2}{R_1 + R_2} \quad \dots \text{R.T.C. of combination at } 0^\circ\text{C}$$

Key Point: Students must derive the result and then use.

$$\therefore \alpha_{12} = \frac{80 \times 0.0038 + 120 \times 0.0018}{80 + 120} = 2.6 \times 10^{-3} / ^\circ\text{C}$$

►► Example 1.53 : In a thermal generating station the heat energy obtained by burning 1 kg of coal is 16,000 kJ. Find the mass of coal required to get an output electrical energy of 1 kWh from the station, if its overall efficiency is 18 %.

[May-2005]

Solution : $m = 1 \text{ kg}$, Heat energy = 16000 kJ, output = 1 kWh, $\eta = 18 \%$

Calorific value of coal = heat energy/kg = 16000 kJ/kg

$$\therefore \text{Total input energy} = m \times 16000 \times 10^3 \text{ J} \quad \dots (1)$$

m = mass of coal burned

Output required = 1 kWh = $1 \times 10^3 \text{ Wh}$

$$= 1 \times 10^3 \times 3600 \text{ W-sec i.e. J}$$

$$\therefore \text{Input required} = \frac{\text{Output energy in J}}{\eta} = \frac{1 \times 10^3 \times 3600}{0.18}$$

$$= 20 \times 10^6 \text{ J} \quad \dots (2)$$

Equating (1) and (2),

$$m \times 16000 \times 10^3 = 20 \times 10^6$$

$$\therefore m = 1.25 \text{ kg} \quad \dots \text{mass of coal required}$$

►► Example 1.54 : Calculate the current required by a 1500 V D.C. locomotive when driving a total load of $100 \times 10^3 \text{ kg}$ at 25 km per hour up on incline of 1 in 100. Assume tractive resistance of 0.069 N/kg and efficiency of motor's gearing as 70 %.

[May-2006]

Solution : The arrangement is shown in the Fig. 1.63.

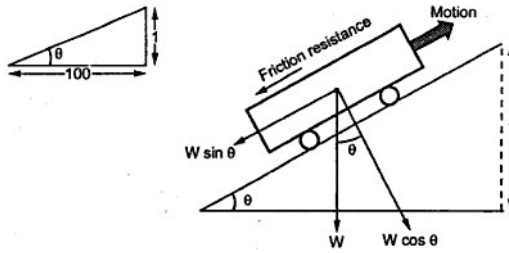

Fig. 1.63

$$\sin \theta = \tan \theta = \frac{1}{100} = 0.01 \quad \dots \theta \text{ is very small}$$

$$W \sin \theta = 100 \times 10^3 \times 0.01 = 1000 \text{ kg} = 9810 \text{ N}$$

$$\text{Track resistance} = 0.069 \text{ N/kg} = 0.069 \times 100 \times 10^3 = 6900 \text{ N}$$

$$\text{Total resistance} = 9810 + 6900 = 16710 \text{ N}$$

$$\text{Work done} = \text{Force} \times \text{distance travelled in 1 sec} = 16710 \times d$$

Now speed = 25 km/hr

$$\therefore d = \frac{25 \times 10^3}{3600} = 6.944 \text{ m in 1 sec}$$

$$\therefore \text{work done} = 16710 \times 6.944 = 116040.924 \text{ J}$$

$$\therefore P_{\text{out}} = \frac{W}{\text{time}} = \frac{116040.924}{1 \text{ sec}} = 116040.924 \text{ W}$$

$$\therefore P_{\text{in}} = \frac{P_{\text{out}}}{\eta_{\text{gear}}} = \frac{116040.924}{0.7} = 165.77274 \times 10^3 \text{ W}$$

But $P_{\text{in}} = V \times I$

$$\therefore I = \frac{P_{\text{in}}}{V} = \frac{165.77274 \times 10^3}{1500} = 110.5151 \text{ A} \quad \dots \text{current required}$$

►► Example 1.55 : A D.C. shunt motor, after running several hours on constant voltage of 400 V, takes field current of 1.6 A. If temperature rise is 40°C, what value of extra resistance is required in field circuit to maintain field current equal to 1.6 A. Assume motor started from cold at 20°C and $\alpha_{20} = 0.0043 / ^\circ\text{C}$. [May-2006]

Solution : $V = 400 \text{ V}$, $I_f = 1.6 \text{ A}$, $\Delta t = 40^\circ\text{C}$, $T_1 = 20^\circ\text{C}$, $\alpha_{20} = 0.0043 / ^\circ\text{C}$

$$R_2 = \frac{V}{I_f} = \frac{400}{1.6} = 250 \Omega$$

... Field circuit resistance after 4 hours at $t_2^\circ\text{C}$

$$R_2 = R_1 [1 + \alpha_1 \Delta t] \quad \text{where } \alpha_1 = \alpha_{20}$$

$$250 = R_1 [1 + 0.0043 \times 40]$$

$$\therefore R_1 = 213.3105 \Omega \quad \text{... Field circuit resistance at } t_1^\circ\text{C}$$

But I_f is to be maintained constant.

$$\therefore I_f = \frac{V}{R_1 + R_x} = 1.6$$

$$\therefore R_1 + R_x = \frac{400}{1.6} = 250$$

$$\therefore R_x = 250 - 213.3105 = 36.6894 \Omega \quad \text{... Extra resistance required.}$$

► **Example 1.56 :** An immersion heater is used for heating 9 liters of water. Its resistance is 50 ohm and has efficiency of 83.6 %. How much time required to heat water from 20°C to 70°C , when connected to 250 V supply. Specific heat capacity of water is $4180 \text{ J/kg}^\circ\text{K}$.

[Dec.-2006, 6 Marks]

Solution : 1 liter = 1 kg, $V = 250 \text{ V}$, $t_2 = 70^\circ\text{C}$, $t_1 = 20^\circ\text{C}$.

$$\therefore m = 9 \text{ kg}, R = 50 \Omega, \eta = 83.6 \%, C = 4187 \text{ J/kg}^\circ\text{K}$$

Output energy = Energy required to heat the water

$$= m C \Delta t = 9 \times 4187 \times (70 - 20) = 1.88415 \times 10^6 \text{ J}$$

$$\therefore \text{Input energy} = \frac{\text{Output}}{\eta} = \frac{1.88415 \times 10^6}{0.836} = 2.2537 \times 10^6 \text{ J}$$

$$P_{\text{in}} = \frac{V^2}{R} = \frac{(250)^2}{50} = 1250 \text{ W}$$

Also,
$$P_{\text{in}} = \frac{\text{Input energy in J}}{\text{Time in sec}}$$

$$\therefore 1250 = \frac{2.2537 \times 10^6}{\text{Time}}$$

$$\therefore \text{Time} = 1802.96 \text{ sec} = 30.05 \text{ min.}$$

► **Example 1.57 :** A single core Cu cable has conductor diameter of 3 cm and insulation thickness of 2 cm. The resistivity of Copper and insulation is 1.73×10^{-8} and 9×10^{12} ohm-meter respectively. Determine resistance of conductor and insulator of the cable for 150 meter length. [Dec.-2007]

Solution : $\rho_c = 1.73 \times 10^{-8} \Omega\text{-m}$, $\rho_i = 9 \times 10^{12} \Omega\text{-m}$, $l = 150 \text{ m}$,

For conductor, $D_1 = \text{diameter} = 3 \text{ cm}$, $R_1 = \frac{D_1}{2} = 1.5 \text{ cm}$

$$\therefore a_c = \frac{\pi}{4} D_1^2 = \frac{\pi}{4} (3)^2 = 7.0685 \text{ cm}^2 = 7.0685 \times 10^{-4} \text{ m}^2$$

$$\therefore R = \frac{\rho_c l}{a_c} = \frac{1.73 \times 10^{-8} \times 150}{7.0685 \times 10^{-4}} = 3.6711 \times 10^{-3} \Omega$$

For insulation, $R_2 = R_1 + t = 1.5 + 2 = 3.5 \text{ cm}$

$$\therefore R_i = \frac{\rho_i}{2\pi l} \ln\left(\frac{R_2}{R_1}\right) = \frac{9 \times 10^{12}}{2\pi \times 150} \ln\left(\frac{3.5}{1.5}\right) = 8.091 \times 10^9 \Omega$$

► **Example 1.58 :** How long it will take to raise the temperature of 880 gm of water from 16 °C to boiling point. The heater takes 2 Amp at 220 V supply and has efficiency of 90 %. [Dec.-2007]

Solution : $m = 880 \text{ gm}$, $\Delta t = 100 \text{ °C} - 16 \text{ °C} = 84$, $\eta = 90 \%$, $I = 2 \text{ A}$, $V = 220 \text{ V}$

For the water, $C = 4190 \text{ J/kg}^\circ\text{K}$

Output Heat required = $m C \Delta t = (880 \times 10^{-3}) \times 4190 \times 84 = 309.7248 \text{ kJ}$

$$\text{Heat input} = \frac{\text{Heat output}}{\eta} = \frac{309.7248}{0.9} = 344.1386 \text{ kJ}$$

power input = $VI = 220 \times 2 = 440 \text{ W}$ i.e. J/s

But power input = $\frac{\text{Heat input}}{\text{Time required}}$

$$\therefore 440 = \frac{344.1386 \times 10^3}{\text{Time required}}$$

$$\therefore \text{Time required} = 782.1333 \text{ sec} = 13.035 \text{ min}$$

► **Example 1.59 :** A resistance element having cross sectional area of 10 mm^2 and length 10 meter takes a current of 4 Amp from 220 V supply at temperature of 20 °C. Find (i) the resistivity of the material and (ii) current it will take when temperature rises 60 °C. Assume $\alpha_{20} = 0.0003 \text{ /}^\circ\text{C}$. [May-200

Solution : $a = 10 \text{ mm}^2 = 10 \times 10^{-6} \text{ m}^2$, $l = 10 \text{ m}$, $I = 4 \text{ A}$, $V = 220 \text{ V}$, $t_1 = 20 \text{ }^\circ\text{C}$

$$\text{i) } R_1 = \frac{V}{I} = \frac{220}{4} = 55 \Omega$$

$$\text{But } R_1 = \frac{\rho l}{a} \quad \text{i.e. } \rho = \frac{R_1 a}{l} = \frac{55 \times 10 \times 10^{-6}}{10}$$

$$\therefore \rho = 55 \times 10^{-6} \Omega\text{-m} \quad \dots \text{Resistivity}$$

$$\text{ii) } t_2 = 60 \text{ }^\circ\text{C}, \quad \alpha_1 = \alpha \text{ at } 20 \text{ }^\circ\text{C} = 0.0003 / ^\circ\text{C}$$

$$R_2 = R_1 [1 + \alpha_1 (t_2 - t_1)] = 55 [1 + 0.0003 (60 - 20)] = 55.66 \Omega$$

$$\therefore \text{New current} = \frac{V}{R_2} = \frac{220}{55.66} = 3.9525 \text{ A}$$

Review Questions

1. What is charge? What is the unit of measurement of charge?
2. Explain the relation between charge and current.
3. What is the difference between e.m.f. and potential difference?
4. What is the resistance? Which are the various factors affecting the resistance?
5. Define the resistivity and conductivity of the material, stating their units.
6. Explain the effect of temperature on the resistance of, i) Metals ii) Insulators and iii) Alloys.
7. Define resistance temperature coefficient. Derive its units.
8. Explain the use of R.T.C. in calculating resistance at $t \text{ }^\circ\text{C}$.
9. Explain the effect of temperature on R.T.C.
10. Write the notes on,
 - i) Mechanical units
 - ii) Electrical units
 - iii) Thermal units
11. An electric kettle is required to heat 10 litres of water from room temperature of $20 \text{ }^\circ\text{C}$ to $100 \text{ }^\circ\text{C}$, in 2 minutes, the supply voltage being 200 V d.c. If the efficiency of kettle is 90% , calculate the resistance of the heating element. Assume the specific heat capacity of water $4190 \text{ J/kg } ^\circ\text{K}$.
(Ans. : 1.2887 Ω)
12. Find the rating of a tin-melting furnace in order to melt 50 kg of tin per hour. The melting temperature of tin is $230 \text{ }^\circ\text{C}$ while its initial temperature is $20 \text{ }^\circ\text{C}$. Specific heat of tin is 0.055 kcal/kg while its latent heat is 13.31 kcal/kg . Assume furnace efficiency as 70% .
(Ans. : 2.0645 kW)
13. An electric kettle contains 1.2 kg of water at $20 \text{ }^\circ\text{C}$. It takes 20 minutes to raise the temperature of the water to $100 \text{ }^\circ\text{C}$. Assuming the heat lost due to radiation and heating the kettle to be 60 kJ , find the current taken by the kettle from the supply of 230 V . Assume specific heat capacity of water to be $4190 \text{ J/kg } ^\circ\text{K}$.
(Ans. : 1.675 A)

14. In a hydroelectric generating station the difference in level (head) between the water surface and the turbine driving the generators is 425 meters. If 1250 litres of water are require to generate 2 kWh of electrical energy, find the over all efficiency. (1 litre of water has a mass of 1 kg).
(Ans. : 69.079 %)
15. An electric lift makes 120 double journeys in a day and a load of 6 tonne is raised to a height of 100 m in one and half minutes. In the return journey the cage of the lift is empty and it completes the journey in 70 secs. The weight of the cage is 600 kg and the counter weight is 3 tonne. Calculate, h.p rating of motor.
Assume the efficiency of the lift as 80 % and that of motor is 88 %. (Ans. : 66 H.P.)
16. One tonne of brass is to be melted in an electric furnace. If the charge is to be melted in 45 min, what is the power input to the furnace ? Assume furnace efficiency as 65 %.
Specific heat of brass is 0.094 cal/gm °K, Latent heat of brass is 40 cal/gm, Melting point of brass is 927 °C. Initial temperature of brass is 25 °C. (Ans. : 297.629 kW)
17. A pump which is gear driven by a d.c. electric motor delivers 1000 kg of water per minute to a tank, 22 m above the level of the pump. If the efficiency of pump is 80% and that of the gearing is 90 % while that of motor is 85 %, what current does the motor take from 400 V supply.
(Ans. : 14.69 A)
18. The field winding of a d.c. machine takes a current of 20 Amp. from 240 V d.c. supply at 25 °C. After a run of a 4 hours, the current drops to 15 Amp, supply voltage remaining constant. Determine its temperature rise.
(Ans. : 86.5 °C)
19. A coil has resistance of 18 Ω at 20 °C and 20 Ω at 50 °C. Find its temperature rise when its resistance is 21 Ω and ambient temperature is 15 °C.
(Ans. : 50 °C)
20. The current at the instant of switching a 40 W, 240 V lamp is 2 Amp. The resistance temperature co-efficient of the filament material is 0.0055 at the room temperature of 20°C. Find the working temperature of lamp.
(Ans. : 2020 °C)
21. The resistance of a copper wire is 50 Ω at a temperature of 35 °C. If the wire is heated to a temperature of 80 °C. find its resistance at that temperature. Assume the temperature co-efficient of resistance of copper at 0 °C to be 0.00427 /°C. Also find the temperature co-efficient at 35 °C.
(Ans. : 58.35 Ω, $3.71 \times 10^{-3} /^{\circ}\text{C}$)
22. The field winding of a d.c. motor is connected across a 440 V supply. When the room temperature is 17°C, winding current is 2.3 A. After the machine has been running for few hours, the current has fallen to 1.9 A, the voltage remaining unaltered. Calculate the average temperature throughout the winding, assuming α_0 of copper = 0.00426 /°C. (Ans. : 70 °C)
23. What is cell and battery ? State and explain the various types of cells.
24. Explain the construction of lead acid battery.
25. Explain first charging, discharging and recharging in case of lead acid battery.
26. State the features and application areas of lead acid battery.
27. State the maintenance procedure for lead acid batteries.
28. How battery capacity is defined ? On which factors it depends ?

29. *What is battery efficiency? In how many ways battery efficiency is expressed ?*
30. *State and explain what is ampere-hour efficiency and watt-hour efficiency.*
31. *Write a note on charge and discharge curves for lead acid battery.*
32. *With a basic charging circuit, explain the battery charging.*
33. *Explain the two methods of battery charging.*
34. *State the indications for fully charged battery.*
35. *Explain the construction of NiMH battery.*
36. *State the cell reactions of NiMH cell.*
37. *State the features of NiMH cell.*
38. *Draw and explain the following characteristics of NiMH batteries,*
 - i) *Discharge characteristics*
 - ii) *Self discharge characteristics*
 - iii) *Charge-voltage characteristics*
39. *State the safety precautions while using the NiMH batteries.*
40. *What are the applications of NiMH batteries.*
41. *Compare Nickel-Cadmium and Nickel metal hydride batteries.*

□□□